



Pneumatic Accessories

ORIGA - *simply the first*

aerospace
climate control
electromechanical
filtration
fluid & gas handling
hydraulics
pneumatics
process control
sealing & shielding



ENGINEERING YOUR SUCCESS.



Contents

Description	Page	Description	Page
Check valves	3–21	Silencer, strainers, Screw-in sieves	41–47
In-line	4	Exhaust silencers (sintered metal), Series D1, D1K	42
Check valves, Series RV	4	Exhaust silencers (plastic), Series D1...K...	43
Check valves, Series RV9	5	Strainers, Series SFS	45
Shuttle valves, Series OR8	33	Screw-in sieves, Series SB .	46–47
– see also special valves			
Quick exhaust valves, Series SV	6	Pressure Switches	49–57
Throttle check valves, Series DRV	7, 8	Pressure switches, pneumatic with plug, Series PR	50
Throttle check valves, Series DRV (plastic version)	9	Pressure switches, pneumatic with screw terminal, Series PR	51
Screw-in		Pressure switches, Series G1/4..I, G1/4..P – with internal thread – flange connection	52–55
Check valves, Series ERV	10–12	Pressure switches, electronic	56, 57
Throttle check valves, Series EDRV	13	Fittings, tubing and accessories	59–126
Throttle check valves, Series EDRV, SEDRV	14–16	Metal push-in fittings	59–68
Throttle check valves, Series SEDRV	17–19	Plastic push-in fittings	69–85
Throttle check valves, Series EDRVK (plastic version)	20	Compression fittings (metal version)	87–97
Throttle check valves, Series EDRV (plastic version)	21	Standard fittings	99–109
Flow control valves	23–30	Sealings	109, 110
In-line		Tube/hose fittings (metal- and plastic versions)	111–113
Flow control valves, Series DV	24, 25	Tubing	114–116
Screw-in		Tubing accessories	116, 117
Flow control valves, Series EDV, SEDV	26, 27	Air line accessories	119–127
Flow control valves, Series SEDV	28, 29	Quick release couplings	121
Exhaust throttle valves, Series DVE	30	Quick release coupling plugs	121, 122
Special valves	31–40	3/2 way slide valves, Series HS	123
AND valves, Series AND8	32	Manifolds with integrated ball valves, Series VL	124
Shuttle valves, Series OR8	33	Ball valves	125, 126
Timer, Series T3P10	34, 35	Blow guns	127
2/2 way screw-in valves (check valves), Series EVP	36, 37		
Miniature screw-in pressure regulators, Series HMR, HMRS	38, 39		
Relief valves, Series USV	40		

Contents

Description	Page
Check valves	4-5
Quick exhaust valves	6
In-line throttle check valves	7-9
Screw-in throttle check valves	10-21

Check valves

- *Check valves*
- *Quick exhaust valves*
- *In-line throttle check valves,*
- *Screw-in throttle check valves*

Metal version
Plastic version



Check valves G1/8, G1/4

In-line version

Series RV

RV series check valves are designed for continuous flow (not suitable for pulsating flow).



Characteristics			Pressures quoted as gauge pressure	
Characteristics	Symbol	Unit	Description	
General features				
Type			Spring loaded check valve	
Mounting			Directly in tubing	
Tube connection			Thread	
Port size			G1/8	G1/4
Weight (mass)		kg	0.02	0.02
Installation				
In any position				
Ambient temperature range	T_{min} T_{max}	°C	-20 +80	Note: When using below freezing point (0 °C) it is necessary to consult us
Medium temperature range	T_{min} T_{max}	°C	0 +80	
Medium			Filtered compressed air, gases, fluids	
Lubrication			Oil mist lubrication compatible with Buna N	
Pneumatic characteristics				
Nominal pressure	p_n	bar	6	
Operating pressure range	p_{min}	bar	0.5	
	p_{max}	bar	10	
Nominal flow	Q_N	l/min	700	1000
Flow direction			In one direction	
Differential pressure for opening the check valve		bar	< 0.5	

Dimensions

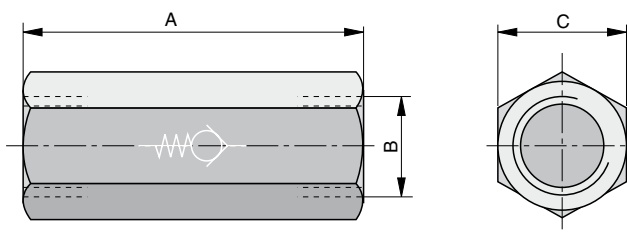

Dimension table and order instructions

Order Instructions		Dimension		
Type	Order No.	A	B	C
RV-06	PA10024	40	G1/8	SW17
RV-08	PA12007	45	G1/4	SW17

Dimensions in mm



Characteristics			Pressures quoted as gauge pressure					
Characteristics	Symbol	Unit	Description					
General features								
Type	Spring loaded check valve							
Mounting	Directly in tubing							
Tube connection	Thread							
Port size			G3/8	G1/2	G3/4	G1	G1 1/4	G1 1/2
Weight (mass)	kg		0.18	0.19	0.27	0.49	0.74	0.98
Installation	In any position							
Ambient- and Medium temperature range	T_{min}	°C	-20		0	-20		
	T_{max}	°C	+110		+90°	+60		
			air		water	gas		
	Note: When using below freezing point (0 °C) it is necessary to consult us							
Medium	Filtered compressed air, cold and warm water, various oils							
Lubrication	Oil mist lubrication compatible with Buna N							
Material	Housing: brass Valve head: stainless steel Seal: synthetic rubber							
Pneumatic characteristics								
Operating pressure range	p_{max}	bar	25	25	25	25	18	18
			at +20°C					
Flow direction	In one direction							

Check valves G3/8 – G1 1/2

In-line version

Series RV9

RV9 series check valves are designed for continuous flow (not suitable for pulsating flow).

Suitable for:
– 100% oxygen
– natural gas
– vacuum



Dimensions

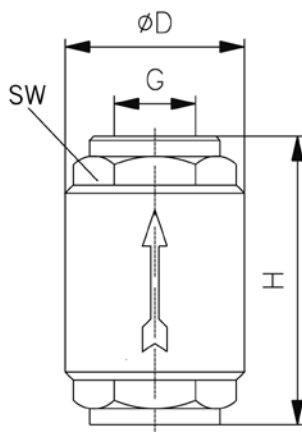

Dimension table and order instructions

Order Instructions		G	ØD	H	SW
Type *	Order No.				
RV9-10	PD 36114	G3/8	34.5	54	23
RV9-15	PD 36335	G1/2	34.5	57	27
RV9-20	PD 36336	G3/4	41.5	64	33
RV9-25	PD 36337	G1	48.0	75	40
RV9-32	PD 36338	G1 1/4	60.5	82	50
RV9-40	PD 36339	G1 1/2	71.0	93	55

* other sizes on request



Dimensions in mm

Quick exhaust valves G1/8 – G3/4

In-line version

Series SV

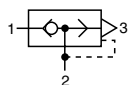

Characteristics		Pressures quoted as gauge pressure					
Characteristics	Symbol	Unit	Description				
General features							
Type	Poppet valve						
Mounting	Directly in tubing						
Tube connection	Thread						
Port size			G1/8	G1/4	G3/8	G1/2	G3/4
Gewicht (Masse)		kg	0.086	0.147	0.150	0.314	0.450
Installation	In any position						
Ambient- and Medium temperature range	T_{min}	°C	-18	Note: When using below freezing point (0 °C) it is necessary to consult us			
	T_{max}	°C	+70				
Material							
– Housing	Brass nickel-plated						
– Membrane	Synthetic material						
Medium	Filtered compressed air						
Lubrication	Oil mist lubrication compatible with Buna N						
Pneumatische characteristics							
Nominal pressure	p_n	bar	6				
Operating pressure range	p_{min}	bar	0.3				
	p_{max}	bar	10				
Nominal flow 1→2	Q_N	l/min	680	1200	2300	3400	3200
Nominal flow 2→3	Q_N	l/min	1100	2100	4900	6100	8750

Dimensions

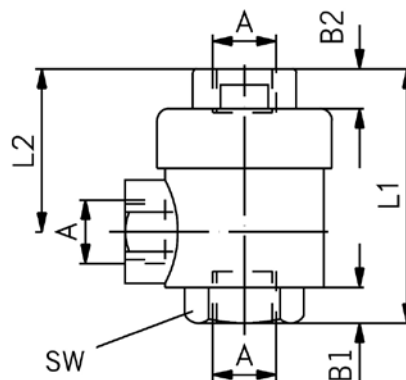

Dimension table and order instructions

Order Instructions		A	B1	B2	L1	L2	SW
Type	Order No.						
SV-06-2	PD39152	G1/8	6.5	6.5	42.0	27	15
SV-08-2	PD39153	G1/4	9.5	9.0	53.0	35	19
SV-10-2	PD39154	G3/8	9.5	9.5	55.5	36	21
SV-15-2	PD39155	G1/2	13.5	13.0	72.0	43	26
SV-20-2	PD39156	G3/4	18.0	18.0	88.0	55	32



Dimensions in mm

Characteristics

Pressures quoted as gauge pressure

Characteristics	Symbol	Unit	Description				
General features							
Type	Throttle valve with parallel check valve						
Mounting	Directly in tubing, 2 through-bolts panel mounting						
Tube connection	Thread						
Port size	M5	G1/8	G1/4	G3/8	G1/2		
Weight (mass)	kg	0.022	0.036	0.132	0.225	0.240	
Installation	In any position						
Ambient temperature range	T_{min}	°C	-20	Note: When using below freezing point (0 °C) it is necessary to consult us			
	T_{max}	°C	+80				
Medium temperature range	T_{min}	°C	0				
	T_{max}	°C	+80				
Medium	Filtered compressed air, lubricated or unlubricated						
Lubrication	Oil mist lubrication compatible with Buna N						
Pneumatic characteristics							
Nominal pressure	p_n	bar	6				
Operating pressure range	p_{min}	bar	0.5				
	p_{max}	bar	10				
Nominal flow ¹⁾ (Throttle valve)	Q_N	l/min	80	125	450	1100	1200
Nominal flow ²⁾ (Check valve)	Q_N	l/min	80	125	450	1100	1200
Differential pressure for opening the check valve		bar	<0.5				

- 1) If the throttle is completely open
2) If the throttle is completely closed

Throttle check valves M5 – G1/2

In-line version

Series DRV

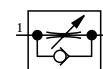

Important:
Please note the flow direction
1 → 2 throttled
2 → 1 free exhaust

Flow characteristics
Type: DRV-M5

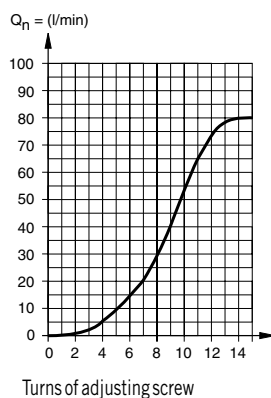

Dimensions in mm

Flow characteristics
Type: DRV-1/8

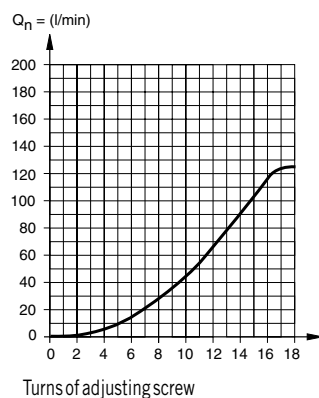

Flow characteristics
Type: DRV-1/4

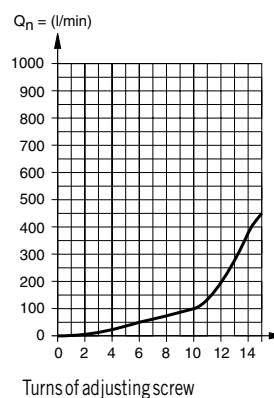

Throttle check valves M5 – G1/2

In-line version

Series DRV

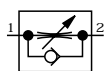

Important:

Please note the flow direction

1 → 2 throttled

2 → 1 free exhaust

Flow characteristics Type: DRV-3/8

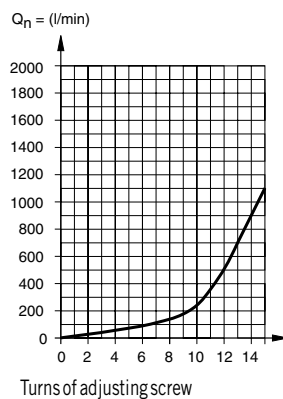

Flow characteristics Type: DRV-1/2

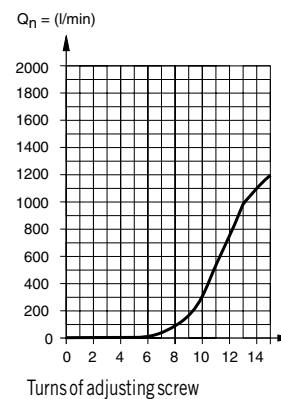

Dimensions

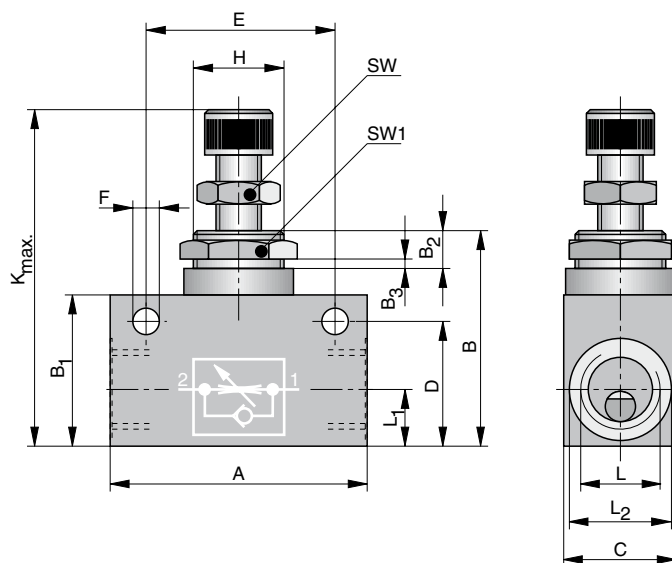

Dimension table and order instructions

Order Instructions	A	B	B ₁	B ₂	B ₃	C	D	E	ØF	H	L	L ₁	ØL ₂	K _{max}	SW	SW ₁
DRV-M5 PA 10232	26.0	26.5	16	6	2.5	14	12.5	18	4.4	M10x1	M5	5.5	8.5	44	7	14
DRV-1/8 PA 10233	32.5	31.5	22	6	2.5	16	17.5	24	4.4	M12x1	G1/8	9.0	13.5	52	10	17
DRV-1/4 PA 12594	55.0	48.0	32	10	4.5	25	25.0	35	6.5	M20x1.5	G1/4	12.0	19.0	72	13	22
DRV-3/8 PA 16143	58.0	57.0	40	10	5.0	30	33.0	43	6.5	M24x1.5	G3/8	13.5	23.0	92	19	27
DRV-1/2 PA 16144	68.0	57.0	40	10	5.0	30	33.0	50	6.5	M24x1.5	G1/2	15.0	27.5	92	19	27

Dimensions in mm

Characteristics

Pressures quoted as gauge pressure

Characteristics	Symbol	Unit	Description					
General features								
Tube connection			Push-in connections					
Tube diameter	ØOD	mm	4	6	8	10	12	
Installation								
Ambient- and Medium temperature range			T _{min}	°C	-20	Note: When using below freezing point (0 °C) it is necessary to consult us		
			T _{max}	°C	+60			
Material			Housing – aluminium/plastic Throttle spindle – brass, anodized Seals – Buna N					
Pneumatische characteristics								
Nominal pressure	p _n	bar	6					
Operating pressure range	p _{min}	bar	0					
	p _{max}	bar	10					
Nominal flow ¹⁾ (Throttle valve)	Q _N	l/min	117	183	300	467	767	
Nominal flow ²⁾ (Check valve)	Q _N	l/min	234	366	600	934	1534	

¹⁾ If the throttle is completely open

²⁾ If the throttle is completely closed

Throttle check valves, plastic, with push-in connections

In-line

Series DRV

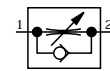

Important:

Please note the flow direction

1 → 2 throttled

2 → 1 free exhaust

Dimensions

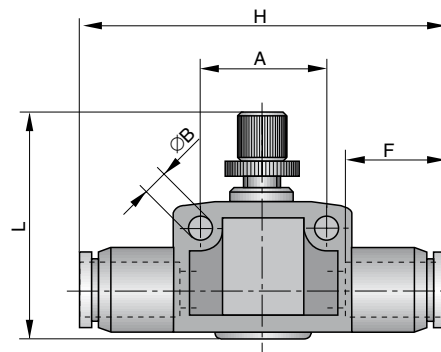

Dimension table and order instructions

Order Instructions		Tube	L _{max}	A	ØB	F	H
Type	Order No.	ØOD					
DRV-4MsvKU	KT0447	4	29.9	15	3.3	16.8	45.1
DRV-6MsvKU	KT0448	6	35.0	20	4.3	17.6	50.3
DRV-8MsvKU	KT0449	8	37.4	23	4.4	18.7	55.7
DRV-10MsvKU	KT0450	10	43.8	28	4.4	19.6	61.2
DRV-12MsvKU	KT0451	12	47.4	32	4.4	21.9	69.8

Dimensions in mm



Screw-in check valves G1/8 – G1/2

Screw-in version

Series DRV

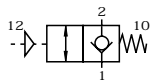

Actuation:
pneumatic deblocking

Characteristics			Pressures quoted as gauge pressure	
Characteristics	Symbol	Unit	Description	
Type			Spring loaded check valve with cone-shaped seal element and elastic seal	
Tube connection			Port 1: internal thread to ISO 228, push-in fitting Port 2: external thread to ISO 228 Port 12: M5, G1/8 internal	
Port size			See dimension table	
Installation			In any position – rings can be rotated 360° after the valve has been installed	
Ambient temperature range	T_{min} T_{max}	°C	-10 +60	Note: When using below freezing point (0 °C) it is necessary to consult us
Medium temperature range	T_{min} T_{max}	°C	-10 +60	
Medium			Filtered compressed air, neutral gases *	
Lubrication			With or without oil mist lubrication ¹⁾	
Material			Metal parts: nickel-plated brass or stainless steel Springs: stainless steel Seals: Buna N Sealing ring: Polyamide	
Pneumatic characteristics				
Nominal pressure	p_n	bar	6	
Operating pressure range	p_{min}	bar	0.3	
	p_{max}	bar	10	
Nominal flow	Q_N	l/min	See table	
Actuation				
pneumatic			Direct	
Actuation pressure range	p_{st}	bar	See diagram	

* other media on request

¹⁾ We recommend the use of mineral oil type VG32 to ISO 3448

Nominal flow, tightening torque, opening pressure, weight (mass)

Port size	DN [mm]	$Q_N 1 \rightarrow 2$ [l/min]	$Q_N 2 \rightarrow 1$ [l/min]	Max. tightening torque [Nm]	$p_{min 2 \rightarrow 1}$ [bar]	Weight mass [kg]
G1/8	3.0	220	280	1.2	0.2	0.068 – no hollow screw 0.048 – with thread G1/8 0.048 – fitting $\varnothing 6$
G1/4	4.4	340	460	1.8	0.2	0.050 – no hollow screw 0.075 – with thread G1/4 0.075 – fitting $\varnothing 6$ 0.082 – fitting $\varnothing 8$
G3/8	5.7	700	910	3.5	0.2	0.150 – with thread G3/8 0.145 – fitting $\varnothing 8$ 0.155 – fitting $\varnothing 10$
G1/2	8.8	1450	1660	4.0	0.15	0.210 – with thread G1/2 0.240 – fitting $\varnothing 12$



Dimensions in mm

Pilot pressure in relation to operating pressure

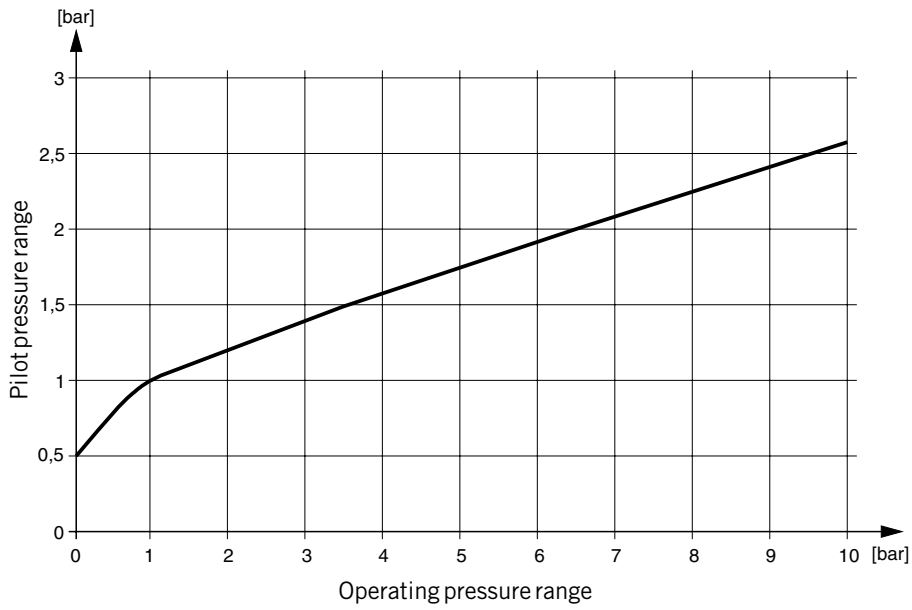

**Screw-in check valves
G1/8 – G1/2**

Screw-in version

Series DRV

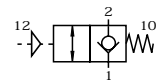

Actuation:
pneumatic deblocking

Example of Control System

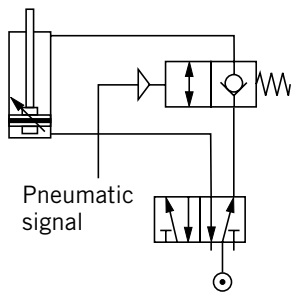

Example of Control System with Vertical Load

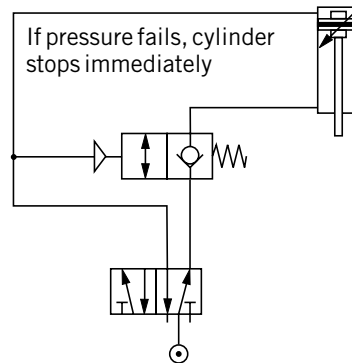

Dimensions in mm



Screw-in check valves G1/8 – G1/2

Screw-in version

Series ERV

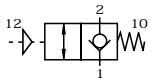

Betätigung:
pneumatisch entsperbar

Dimensions

Version with internal thread

Version with push-in fitting

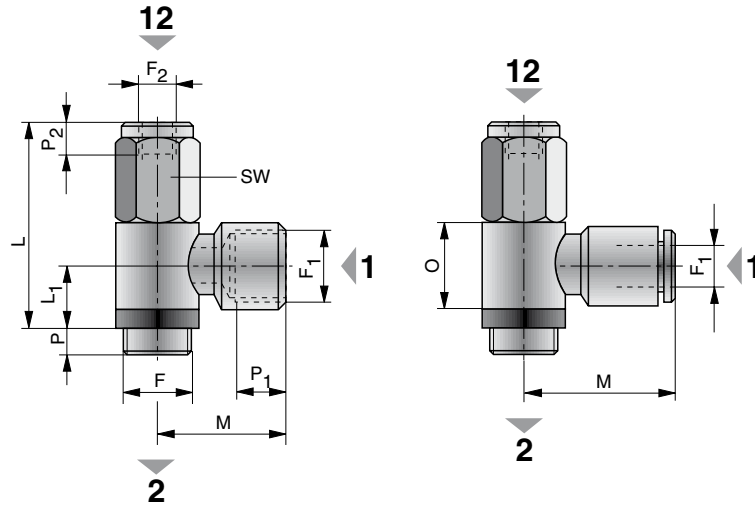

Dimension table and order instructions

Order Instructions		F	F ₁	F ₂	L	L ₁	M	O	P	P ₁	P ₂	SW
Type	Order No.											
ERV-1/8	KL4077	G1/8	G1/8	M5	37.5	12.5	21.0	15	6.5	7	6	14
ERV-1/8	KL4078	G1/8	∅ 6	M5	37.5	12.5	25.0	15	6.5	–	6	14
ERV-1/4	KL4080	G1/4	G1/4	G1/8	42.5	13.5	25.0	17	7.0	8	7	17
ERV-1/4	KL4081	G1/4	∅ 6	G1/8	42.5	13.5	27.5	17	7.0	–	7	17
ERV-1/4	KL4082	G1/4	∅ 8	G1/8	42.5	13.5	32.0	17	7.0	–	7	17
ERV-3/8	KL4083	G3/8	G3/8	G1/8	46.0	15.0	31.0	20	9.0	10	7	19
ERV-3/8	KL4084	G3/8	∅ 8	G1/8	46.0	15.0	31.5	20	9.0	–	7	19
ERV-3/8	KL4085	G3/8	∅ 10	G1/8	46.0	15.0	36.0	20	9.0	–	7	19
ERV-1/2	KL4086	G1/2	G1/2	G1/8	51.5	17.0	40.0	24	10.0	14	7	24
ERV-1/2	KL4087	G1/2	∅ 12	G1/8	51.5	17.0	40.5	24	10.0	–	7	24



Dimensions in mm

Characteristics			Pressures quoted as gauge pressure	
Characteristics	Symbol	Unit	Description	
General features				
Type	Spring loaded throttle check valve			
Mounting	Screw-in valve			
Tube connection	Thread			
Port size			G1/8	G1/4
Weight (mass)		kg	0.03	0.04
Installation	In any position			
Ambient temperature range	T_{min} T_{max}	°C	-10 +60	Note: When using below freezing point (0 °C) it is necessary to consult us
Medium temperature range	T_{min} T_{max}	°C	-10 +60	
Medium	Filtered compressed air			
Lubrication	Oil mist lubrication compatible with Buna N			
Pneumatic characteristics				
Nominal pressure	p_n	bar	6	
Operating pressure range	p_{min}	bar	0.5	
	p_{max}	bar	10	
Nominal flow throttle valve (throttle completely open)	Q_N	l/min	250	400
Nominal flow check valve (throttle completely closed)	Q_N	l/min	350	450

Screw-in throttle check valves G1/8, G1/4

Screw-in version

Series EDRV

for air outlet throttling

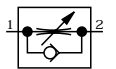

Speed regulating valve

This valve is used for regulating the piston speed of pneumatic cylinders.

Dimensions

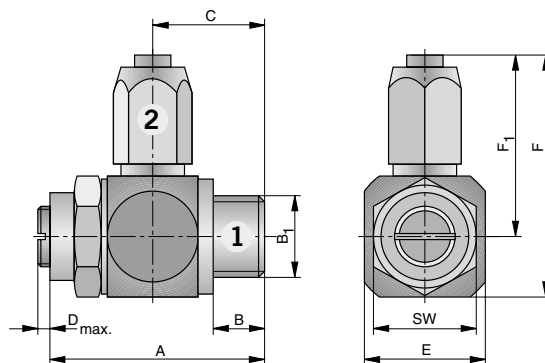

Dimension table and order instructions

Order Instructionsn		Tube	A	B	B ₁	C	D _{max}	E	F	F ₁	SW
Type	Order No.	ØOD/ID									
EDRV-06-5/3	PA 10018	5/3	34	8.0	G1/8	16.5	1.0	16	18.5	26.5	14
EDRV-06-6/4	PA 10019	6/4	34	8.0	G1/8	16.5	1.0	16	21.5	29.5	14
EDRV-06-8/6	PA 10020	8/6	34	8.0	G1/8	16.5	1.0	16	22.5	30.5	14
EDRV-08-6/4	PA 12001	6/4	38	10.5	G1/4	19.5	1.2	20	23.0	33.0	17
EDRV-08-8/6	PA 12002	8/6	38	10.5	G1/4	19.5	1.2	20	24.0	34.0	17
EDRV-08-10/8	PA 12003	10/8	38	10.5	G1/4	19.5	1.2	20	26.0	36.0	17

Dimensions in mm



Screw-in throttle check valves M5 – G1/4

Screw-in version

Series EDRV
Series SEDRV

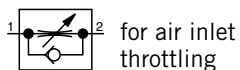
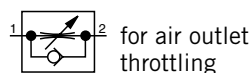

Versions
– with tube connection
– for air inlet and air outlet throttling

This valve is used for regulating the piston speed of pneumatic cylinders.

Characteristics			Pressures quoted as gauge pressure		
Characteristics	Symbol	Unit	Description		
General features					
Mounting			Screw-in valve		
Tube connection			Thread		
Port size			M5	G1/8	G1/4
Installation			In any position		
Mediums- und Ambient temperature range			T_{\min}	°C	0
			T_{\max}	°C	+80
Note: When using below freezing point (0 °C) it is necessary to consult us					
Material					
– Housing			Brass nickel-plated		
– O-ring			Buna N		
– Seals			Synthetic material		
Medium			Filtered compressed air		
Lubrication			Oil mist lubrication compatible with Buna N		
Pneumatische characteristics					
Nominal pressure			p_n	bar	6
Operating pressure range			p_{\max}	bar	10
Nominal flow			M5	G1/8	G1/4
Type SEDRV-...A			Q_N	l/min	Ø4/2 – 45
Type SEDRV			Q_N	l/min	Ø4/2 – 310 Ø5/3 – 310 Ø6/4 – 390 Ø8/6 – 390
Type EDRV			Q_N	l/min	Ø5/3 – 310 Ø6/4 – 310 Ø8/6 – 310
Type EDRV			Q_N	l/min	310 450



Dimensions in mm

Screw-in throttle check valves
Type: EDRV-....BI

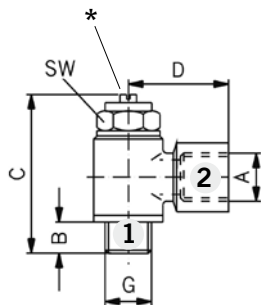

* Throttle screw

Screw-in throttle check valves
Type: EDRV-....B

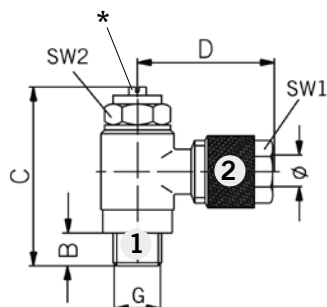

* Throttle screw

Screw-in throttle check valves
Type: SEDRV-....B

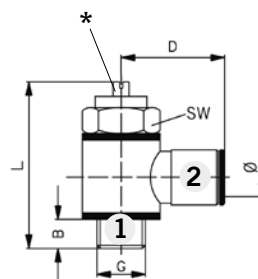

* Throttle screw

Screw-in throttle check valves M5 – G1/4

Screw-in version

Series EDRV
Series SEDRV

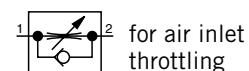

Screw-in throttle check valves with push-in fittings – Type SEDRV-....B
Dimension table and order instructions

Order Instructions		∅	G	B	D	L	SW
Type	Order No.						
SEDRV-184B	KW 0530	4/2	G1/8	5.5	21.0	31.5	14
SEDRV-185B	KW 0531	5/3	G1/8	5.5	22.5	31.5	14
SEDRV-186B	KW 0532	6/4	G1/8	5.5	22.5	31.5	14
SEDRV-146B	KW 0533	6/4	G1/4	6.0	24.0	38.0	17
SEDRV-188B	KW 0534	8/6	G1/8	5.5	24.5	31.5	14
SEDRV-148B	KW 0535	8/6	G1/4	6.0	26.0	38.0	17
SEDRV-1410B	KW 0536	10/8	G1/4	6.0	28.0	38.0	17

Screw-in throttle check valves with union nut – Type EDRV-....B
Dimension table and order instructions

Order Instructions		∅	G	B	C	D	SW1	SW2
Type	Order No.							
EDRV-185B	KW 0540	5/3	G1/8	5.5	36	23.0	8	14
EDRV-186B	KW 0541	6/4	G1/8	5.5	36	23.0	10	14
EDRV-146B	KW 0542	6/4	G1/4	6.0	38	26.0	10	17
EDRV-188B	KW 0543	8/6	G1/8	5.5	36	23.0	12	14
EDRV-148B	KW 0544	8/6	G1/4	6.0	38	26.0	12	17

Screw-in throttle check valves with internal thread – Type EDRV-....BI
Dimension table and order instructions

Order Instructions		G	B	C	D	SW
Type	Order No.					
EDRV-1818BI	KW 0537	G1/8	4.5	36.0	16.0	14
EDRV-1414BI	KW 0538	G1/4	6.5	38.0	25.5	17

Dimensions in mm



Screw-in throttle check valves M5 – G1/4

Screw-in version

Series EDRV
Series SEDRV

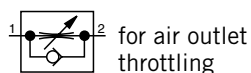

Screw-in throttle check valves
Type: EDRV-....AI

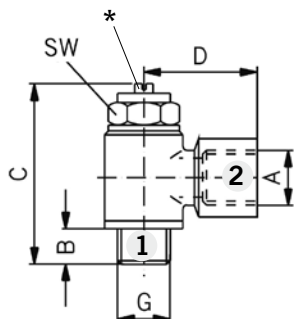

* Throttle screw

Screw-in throttle check valves
Type: EDRV-....A

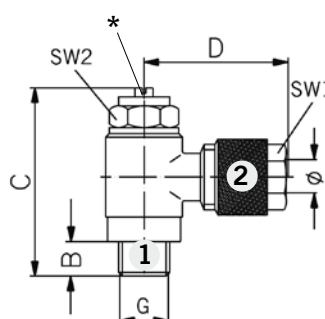

* Throttle screw

Screw-in throttle check valves
Type: SEDRV-....A

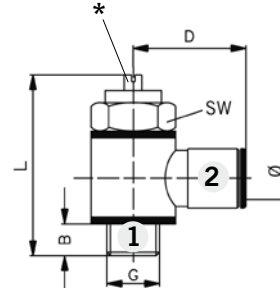

* Throttle screw

Screw-in throttle check valves with push-in fittings – Type SEDRV-....A
Dimension table and order instructions

Order Instructions		Ø	G	B	D	L	SW
Type	Order No.						
SEDRV-54A	KW0511	4/2	M5	6.0	17.0	24.5	8
SEDRV-184A	KW0512	4/2	G1/8	5.5	21.0	31.5	14
SEDRV-55A	KW0513	5/3	G1/8	5.5	22.5	31.5	14
SEDRV-186A	KW0515	6/4	G1/8	5.5	22.5	31.5	14
SEDRV-146A	KW0516	6/4	G1/4	6.0	24.0	38.0	17
SEDRV-188A	KW0517	8/6	G1/8	5.5	24.5	31.5	14
SEDRV-148A	KW0518	8/6	G1/4	6.0	26.0	38.0	17
SEDRV-1410A	KW0519	10/8	G1/4	6.0	28.0	38.0	17

Screw-in throttle check valves with union nut – Type EDRV-....A
Dimension table and order instructions

Order Instructions		Ø	G	B	C	D	SW1	SW2
Type	Order No.							
EDRV-185A	KW0524	5/3	G1/8	5.5	36	23.0	8	14
EDRV-186A	KW0525	6/4	G1/8	5.5	36	23.0	10	14
EDRV-146A	KW0526	6/4	G1/4	6.0	38	26.0	10	17
EDRV-188A	KW0527	8/6	G1/8	5.5	36	23.0	12	14
EDRV-148A	KW0528	8/6	G1/4	6.0	38	26.0	12	17

Screw-in throttle check valves with internal thread – Type EDRV-....AI
Dimension table and order instructions

Order Instructions		G	B	C	D	SW
Type	Order No.					
EDRV-1818AI	KW0520	G1/8	4.5	36.0	16.0	14
EDRV-1414AI	KW0521	G1/4	6.5	38.0	25.5	17



Dimensions in mm

Characteristics			Pressures quoted as gauge pressure	
Characteristics	Symbol	Unit	Description	
General features				
Mounting		Screw-in valve		
Tube connection		Thread		
Port size		G1/8	G1/4	
Installation		In any position		
Mediums- und Ambient temperature range		T_{min} T_{max}	°C °C	0 +80 Note: When using below freezing point (0 °C) it is necessary to consult us
Material				
– Housing		Brass nickel-plated		
– O-ring		Buna N		
– Seals		Synthetic material		
Medium		Filtered compressed air		
Lubrication		Oil mist lubrication compatible with Buna N		
Pneumatic characteristics				
Nominal pressure		p_n	bar	6
Operating pressure range		p_{max}	bar	10
Nominal flow		G1/8	G1/4	
Type SEDRV-....Msv		Q_N	l/min	Ø4/2–310 Ø6/4–390 Ø8/6–390
				Ø6/4–710 Ø8/6–810 Ø10/8–810 Ø12/10–810

Screw-in throttle check valves G1/8, G1/4

Screw-in version

Series SEDRV

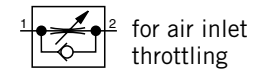
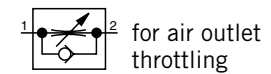

Versions
–with tube connection
–for air inlet and air outlet throttling

This valve is used for regulating the piston speed of pneumatic cylinders.

Dimensions in mm



Screw-in throttle check valves G1/8, G1/4

Screw-in version

Series SEDRV

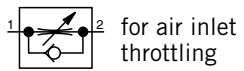

Screw-in throttle check valves Type: SEDRV-....B

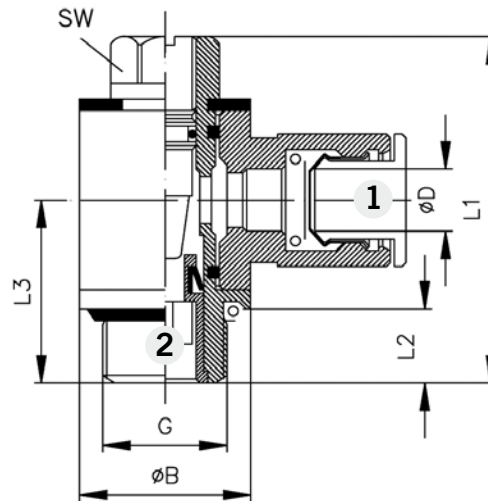

Screw-in throttle check valves with push-in fittings – Type SEDRV-....B
Dimension table and order instructions

Order Instructions		ØD	G	ØB	L1	L2	L3	SW
Type	Order No.							
SEDRV-184B-Msv	KW 1004	4/2	G1/8	14	32	6	15.0	9
SEDRV-186B-Msv	KW 1006	6/4	G1/8	14	32	6	15.0	9
SEDRV-146B-Msv	KW 1008	6/4	G1/4	18	37	8	18.5	12
SEDRV-188B-Msv	KW 1007	8/6	G1/8	14	32	6	15.0	9
SEDRV-148B-Msv	KW 1009	8/6	G1/4	18	37	8	18.5	12
SEDRV-1410B-Msv	KW 1010	10/8	G1/4	18	37	8	18.5	12
SEDRV-1412B-Msv	KW 1011	12/10	G1/4	18	37	8	18.5	12



Dimensions in mm

Screw-in throttle check valves Type: SEDRV-....A

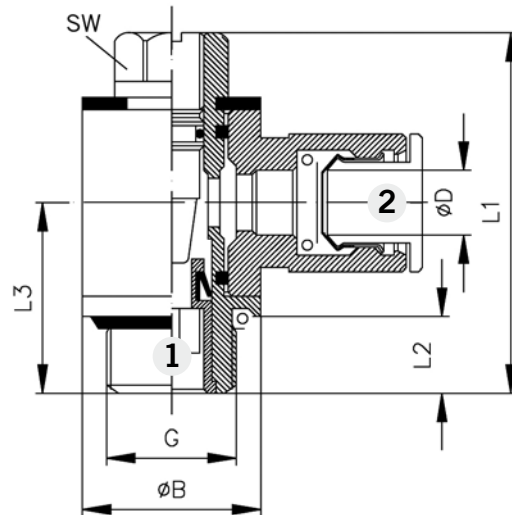

**Screw-in
throttle check
valves
G1/8, G1/4**

Screw-in version

Series SEDRV

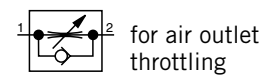

**Screw-in throttle check valves with push-in fittings – Type SEDRV-....A
Dimension table and order instructions**

Order Instructions	Order No.	ØD	G	ØB	L1	L2	L3	SW
SEDRV-184A-Msv	KW 1018	4/2	G1/8	14	32	6	15.0	9
SEDRV-186A-Msv	KW 1020	6/4	G1/8	14	32	6	15.0	9
SEDRV-146A-Msv	KW 1022	6/4	G1/4	18	37	8	18.5	12
SEDRV-188A-Msv	KW 1021	8/6	G1/8	14	32	6	15.0	9
SEDRV-148A-Msv	KW 1023	8/6	G1/4	18	37	8	18.5	12
SEDRV-1410A-Msv	KW 1024	10/8	G1/4	18	37	8	18.5	12
SEDRV-1412A-Msv	KW 1025	12/10	G1/4	18	37	8	18.5	12

Dimensions in mm



Screw-in throttle check valves M5 – G1/4

Screw-in version

Series EDRVK

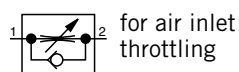

Version:

- Short design, with slot and hexagon socket

Series EDRVK

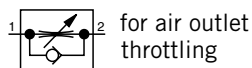

Version:

- Short design, with slot and hexagon socket

Screw-in throttle check valve Type: EDRVK-...B, EDRVK-...A

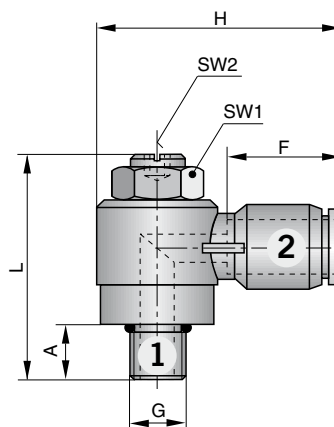

Dimension table and order instructions – Type: EDRVK-...B – for air inlet throttling

Order Instructions	G	Tube ØOD	A	L _{max} *	H	F	SW1	SW2	Q _N [Nl/min]	
Type	Order No.									
EDRVK-54B-MsvKU	KT0452	M5	4	3.6	23.1	25.1	16.3	8	–	130
EDRVK-56B-MsvKU	KT0453	M5	6	3.6	23.1	27.8	17.6	8	2	130
EDRVK-184B-MsvKU	KT0454	G1/8	4	6.0	30.4	30.5	16.3	8	2	300
EDRVK-186B-MsvKU	KT0455	G1/8	6	6.0	30.4	31.2	17.6	8	2	400
EDRVK-188B-MsvKU	KT0456	G1/8	8	6.0	30.4	33.0	18.7	8	2	400
EDRVK-146B-MsvKU	KT0457	G1/4	6	8.0	36.3	35.0	17.6	12	2	620
EDRVK-148B-MsvKU	KT0458	G1/4	8	8.0	36.3	36.8	18.7	12	2	720
EDRVK-1410B-MsvKU	KT0459	G1/4	10	8.0	36.3	38.8	19.6	12	2	720

Material: plastic/nickel-plated brass

*If the throttle is completely open

Dimension table and order instructions – Type: EDRVK-...A – for air outlet throttling

Order Instructions	G	Tube ØOD	A	L _{max} *	H	F	SW1	SW2	Q _N [Nl/min]	
Type	Order No.									
EDRVK-54A-MsvKU	KT0460	M5	4	3.6	23.1	25.1	16.3	8	–	130
EDRVK-56A-MsvKU	KT0461	M5	6	3.6	23.1	27.8	17.6	8	2	130
EDRVK-184A-MsvKU	KT0462	G1/8	4	6.0	30.4	30.5	16.3	8	2	300
EDRVK-186A-MsvKU	KT0463	G1/8	6	6.0	30.4	31.2	17.6	8	2	400
EDRVK-188A-MsvKU	KT0464	G1/8	8	6.0	30.4	33.0	18.7	8	2	400
EDRVK-146A-MsvKU	KT0465	G1/4	6	8.0	36.3	35.0	17.6	12	2	620
EDRVK-148A-MsvKU	KT0466	G1/4	8	8.0	36.3	36.8	18.7	12	2	720
EDRVK-1410A-MsvKU	KT0467	G1/4	10	8.0	36.3	38.8	19.6	12	2	720

Material: plastic/nickel-plated brass

*If the throttle is completely open



Dimensions in mm

Screw-in throttle check valve Type: EDRV-...B, EDRV-...A

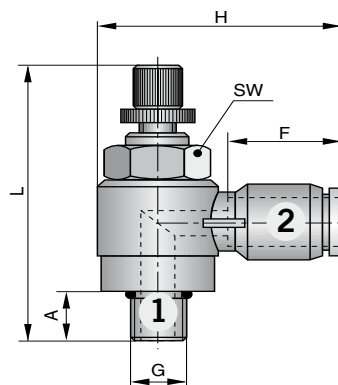

Screw-in throttle check valves M5 – G1/2

Screw-in version

Series EDRV

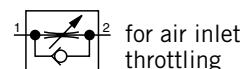

Dimension table and order instructions – Type: EDRV-...B – for air inlet throttling

Order Instructions	Order No.	Tube ØOD	G	A	L _{max} *	H	F	SW	Q _N [Nl/min]
EDRV-54B-MsvKU	KT0417	4	M5	4.6	37.0	26.6	16.8	8	100
EDRV-56B-MsvKU	KT0418	6	M5	4.6	37.0	27.2	17.6	8	100
EDRV-184B-MsvKU	KT0419	4	G1/8	4.5	40.1	30.9	16.3	8	165
EDRV-186B-MsvKU	KT0420	6	G1/8	4.5	40.1	31.4	17.6	8	165
EDRV-188B-MsvKU	KT0421	8	G1/8	4.5	40.1	34.2	18.7	8	165
EDRV-146B-MsvKU	KT0422	6	G1/4	5.5	47.6	35.6	17.6	12	410
EDRV-148B-MsvKU	KT0423	8	G1/4	5.5	47.6	38.3	18.7	12	410
EDRV-1410B-MsvKU	KT0424	10	G1/4	5.5	47.6	39.5	19.6	12	410
EDRV-1412B-MsvKU	KT0425	12	G1/4	5.5	47.6	41.8	21.9	12	410
EDRV-386B-MsvKU	KT0426	6	G3/8	6.0	55.9	39.0	17.6	12	500
EDRV-388B-MsvKU	KT0427	8	G3/8	6.0	55.9	40.0	18.7	12	500
EDRV-3810B-MsvKU	KT0428	10	G3/8	6.0	55.9	42.5	19.6	12	500
EDRV-3812B-MsvKU	KT0429	12	G3/8	6.0	55.9	45.5	21.9	12	500
EDRV-1210B-MsvKU	KT0430	10	G1/2	7.0	59.6	47.1	19.6	19	900
EDRV-1212B-MsvKU	KT0431	12	G1/2	7.0	59.6	50.3	21.9	19	900

Material: plastic/nickel-plated brass

*If the throttle is completely open

Series EDRV

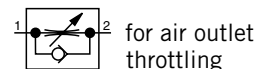

Dimension table and order instructions – Type: EDRV-...A – for air outlet throttling

Order Instructions	Order No.	Tube ØOD	G	A	L _{max} *	H	F	SW	Q _N [Nl/min]
EDRV-54A-MsvKU	KT0432	4	M5	4.6	37.0	26.6	16.8	8	100
EDRV-56A-MsvKU	KT0433	6	M5	4.6	37.0	27.2	17.6	8	100
EDRV-184A-MsvKU	KT0434	4	G1/8	4.5	40.1	30.9	16.3	8	165
EDRV-186A-MsvKU	KT0435	6	G1/8	4.5	40.1	31.4	17.6	8	165
EDRV-188A-MsvKU	KT0436	8	G1/8	4.5	40.1	34.2	18.7	8	165
EDRV-146A-MsvKU	KT0437	6	G1/4	5.5	47.6	35.6	17.6	12	410
EDRV-148A-MsvKU	KT0438	8	G1/4	5.5	47.6	38.3	18.7	12	410
EDRV-1410A-MsvKU	KT0439	10	G1/4	5.5	47.6	39.5	19.6	12	410
EDRV-1412A-MsvKU	KT0440	12	G1/4	5.5	47.6	41.8	21.9	12	410
EDRV-386A-MsvKU	KT0441	6	G3/8	6.0	55.9	39.0	17.6	12	500
EDRV-388B-MsvKU	KT0442	8	G3/8	6.0	55.9	40.0	18.7	12	500
EDRV-3810B-MsvKU	KT0443	10	G3/8	6.0	55.9	42.5	19.6	12	500
EDRV-3812B-MsvKU	KT0444	12	G3/8	6.0	55.9	45.5	21.9	12	500
EDRV-1210B-MsvKU	KT0445	10	G1/2	7.0	59.6	47.1	19.6	19	900
EDRV-1212B-MsvKU	KT0446	12	G1/2	7.0	59.6	50.3	21.9	19	900

Material: plastic/nickel-plated brass

*If the throttle is completely open

Dimensions in mm



Contents

Description	Page
In-line flow control valves	24, 25
Screw-in flow control valves	26–29
Exhaust throttle valves	30

Flow control valves

- *In-line flow control valves*
- *Screw-in flow control valves*

Metal version



Flow control valves

M5 – G1/2

In-line version

Series DV



Characteristics		Pressures quoted as gauge pressure						
Characteristics	Symbol	Unit	Description					
General features								
Type	Throttle valve							
Mounting	Directly in tubing 2 through-bolts panel mounting							
Tube connection	Thread							
Port size			M5	G1/8	G1/4	G3/8	G1/2	
Weight (mass)			kg	0.015	0.038	0.138	0.225	0.245
Installation	In any position							
Ambient temperature range	T_{min}	°C	-20	Note: When using below freezing point (0 °C) it is necessary to consult us				
	T_{max}	°C	+80					
Medium temperature range	T_{min}	°C	0					
	T_{max}	°C	+80					
Medium	Filtered, lubricated or unlubricated compressed air							
Lubrication	Oil mist lubrication compatible with Buna N							
Pneumatic characteristics								
Nominal pressure	p_n	bar	6					
Operating pressure range	p_{min}	bar	0.5					
	p_{max}	bar	10					
Nominal flow when throttle is completely open	Q_N	l/min	80	125	450	1100	1200	

Flow characteristics
Type: DV-M5

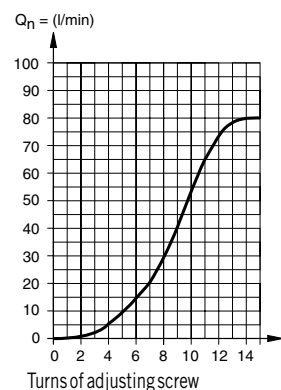

Flow characteristics
Type: DV-1/8

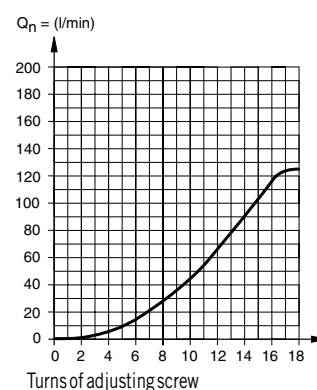

Flow characteristics
Type: DV-1/4

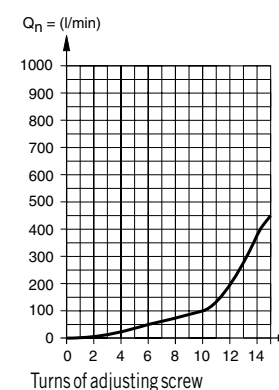

Dimensions in mm

Flow characteristics
Type: DV-3/8

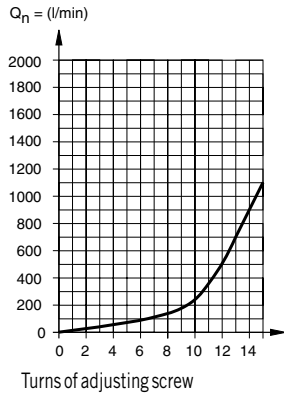

Flow characteristics
Type: DV-1/2

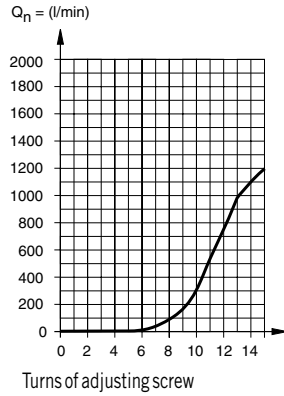

Flow control valves
M5 – G1/2

In-line version

Series DV

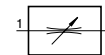

Dimensions

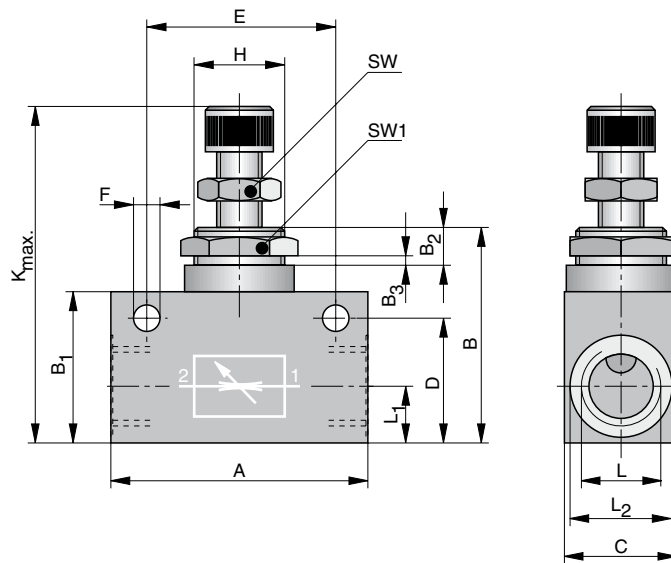

Dimension table and order instructions

Order Instructions		A	B	B ₁	B ₂	B ₃	C	D	E	ØF	H	L	L ₁	ØL ₂	K _{max}	SW	SW ₁
Type	Order No.																
DV-M5	PA 10230	26.0	26.5	16	6	2.5	14	12.5	18	4.4	M10x1	M5	5.5	8.5	44	7	14
DV-1/8	PA 10231	32.5	31.5	22	6	2.5	16	17.5	24	4.4	M12x1	G1/8	9.0	13.5	52	10	17
DV-1/4	PA 12593	55.0	48.0	32	10	4.5	25	25.0	35	6.5	M20x1.5	G1/4	12.0	19.0	72	13	22
DV-3/8	PA 16141	58.0	57.0	40	10	5.0	30	33.0	43	6.5	M24x1.5	G3/8	13.5	23.0	92	19	27
DV-1/2	PA 16142	68.0	57.0	40	10	5.0	30	33.0	50	6.5	M24x1.5	G1/2	15.0	27.5	92	19	27

Dimensions in mm

Flow control valves M5 – G1/4

Screw-in version

Series EDV, SEDV

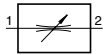

– with tube connection

Characteristics			Pressures quoted as gauge pressure		
Characteristics	Symbol	Unit	Description		
General features					
Mounting			Screw-in valve		
Tube connection			Thread		
Port size			M5	G1/8	G1/4
Installation			In any position		
Mediums- und Ambient temperature range		T_{min} T_{max}	°C °C	-0 +80	Note: When using below freezing point (0 °C) it is necessary to consult us
Material					
– Housing			Brass nickel-plated		
– O-rings			Buna N		
– Seals			Synthetic material		
Medium			Filtered compressed air		
Lubrication			Oil mist lubrication compatible with Buna N		
Pneumatic characteristics					
Nominal pressure		p_n	bar	6	
Operating pressure range		p_{max}	bar	10	
Nominal flow			M5	G1/8	G1/4
Type SEDV-..C		Q_N	l/min	Ø4/2 – 45	
Type SEDV-....C		Q_N	l/min	Ø4/2 – 310 Ø5/3 – 310 Ø6/4 – 390 Ø8/6 – 390	Ø6/4 – 710 Ø8/6 – 810 Ø10/8 – 810
Type EDV-....C		Q_N	l/min	Ø6/4 – 310 Ø8/6 – 310	Ø6/4 – 420 Ø8/6 – 420
Type EDV-....CI		Q_N	l/min	310	450



Dimensions in mm

Screw-in flow control valves
Type: EDV-....CI

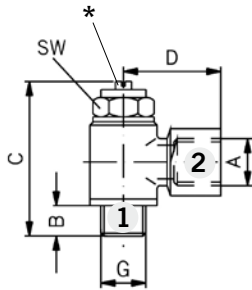

* Throttle screw

Screw-in flow control valves
Type: EDV-....C

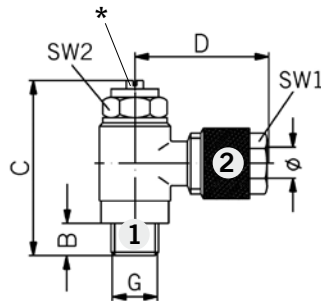

* Throttle screw

Screw-in flow control valves
Type: SEDV-....C

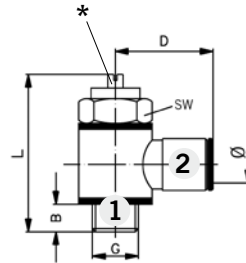

* Throttle screw

Flow control valves M5 – G1/4

Screw-in version

Series EDV, SEDV

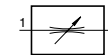

– with tube connection

Screw-in flow control valves with push-in fittings – Type SEDV-....C
Dimension table and order instructions

Order Instructions	Order No.	Ø	G	B	D	L	SW
SEDV-54C	KW 0546	4/2	M5	6.0	17.0	24.5	8
SEDV-184C	KW 0547	4/2	G1/8	5.5	21.0	31.5	14
SEDV-185C	KW 0549	5/3	G1/8	5.5	22.5	31.5	14
SEDV-186C	KW 0550	6/4	G1/8	5.5	22.5	31.5	14
SEDV-146C	KW 0551	6/4	G1/4	6.0	24.0	38.0	17
SEDV-188C	KW 0552	8/6	G1/8	5.5	24.5	31.5	14
SEDV-148C	KW 0553	8/6	G1/4	6.0	26.0	38.0	17
SEDV-1410C	KW 0554	10/8	G1/4	6.0	28.0	38.0	17

Screw-in flow control valves with union nut – Type EDV-....C
Dimension table and order instructions

Order Instructions	Order No.	Ø	G	B	C	D	SW1	SW2
EDV-186C	KW 0560	6/4	G1/8	5.5	36	23.0	10	14
EDV-146C	KW 0561	6/4	G1/4	6.0	38	26.0	10	17
EDV-188C	KW 0562	8/6	G1/8	5.5	36	23.0	12	14
EDV-148C	KW 0563	8/6	G1/4	6.0	38	26.0	12	17

Screw-in flow control valves with internal thread – Type EDV-....CI
Dimension table and order instructions

Order Instructions	Order No.	G	B	C	D	SW
EDV-1818CI	KW 0555	G1/8	4.5	36.0	16.0	14
EDV-1414CI	KW 0556	G1/4	6.5	38.0	25.5	17

Dimensions in mm



Flow control valves G1/8, G1/4

Screw-in version

Series SEDV

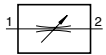

– with tube connection

This valve is used for regulating the piston speed of pneumatic cylinders.



Characteristics			Pressures quoted as gauge pressure	
Characteristics	Symbol	Unit	Description	
General features				
Mounting			Screw-in valve	
Tube connection			Thread	
Port size			G1/8	G1/4
Installation			In any position	
Ambient- and Medium temperature range	T_{min} T_{max}	°C °C	0 +80	Note: When using below freezing point (0 °C) it is necessary to consult us
Material				
– Housing			Brass nickel-plated	
– O-rings			Buna N	
– Seals			Synthetic material	
Medium			Filtered compressed air	
Lubrication			Oil mist lubrication compatible with Buna N	
Pneumatic characteristics				
Nominal pressure	p_n	bar	6	
Operating pressure range	p_{max}	bar	10	
Nominal flow			G1/8	G1/4
Type SEDRV-....Msv	Q_N	l/min	Ø4/2–310 Ø6/4–390 Ø8/6–390	Ø6/4–710 Ø8/6–810 Ø10/8–810 Ø12/10–810

Dimensions in mm

Screw-in flow control valves – Type SEDV-...

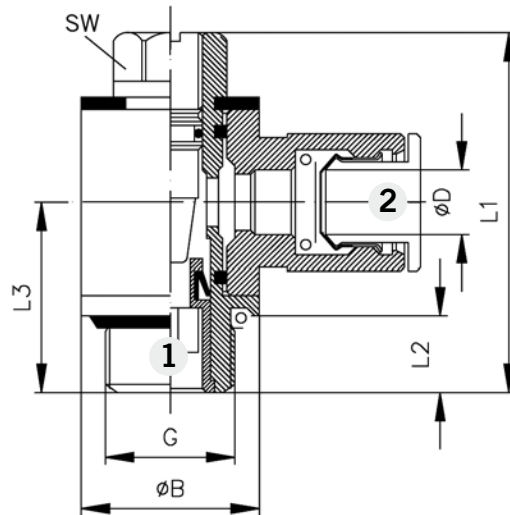

Flow control valves G1/8, G1/4

Screw-in version

Series SEDV

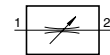

– with tube connection

This valve is used for regulating the piston speed of pneumatic cylinders.

**Screw-in flow control valves with push-in fittings – Type SEDV-...
Dimension table and order instructions**

Order Instructions		ØD	G	ØB	L1	L2	L3	SW
Type	Order No.							
SEDV-184-Msv	KW 1032	4/2	G1/8	14	32	6	15.0	9
SEDV-186-Msv	KW 1034	6/4	G1/8	14	32	6	15.0	9
SEDV-188-Msv	KW 1035	6/4	G1/4	18	37	8	18.5	12
SEDV-146-Msv	KW 1036	8/6	G1/8	14	32	6	15.0	9
SEDV-148-Msv	KW 1037	8/6	G1/4	18	37	8	18.5	12
SEDV-1410-Msv	KW 1038	10/8	G1/4	18	37	8	18.5	12
SEDV-1412-Msv	KW 1039	12/10	G1/4	18	37	8	18.5	12



Dimensions in mm

Exhaust throttle valves G1/8 – G1/2

Series DVE

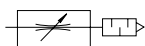

Dimensions

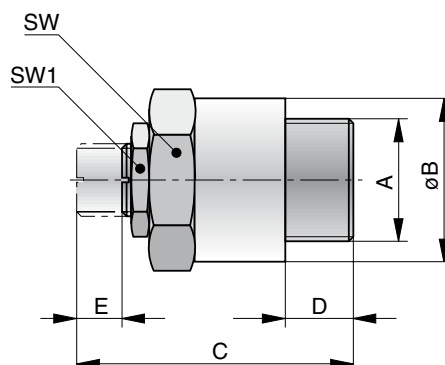

Exhaust throttle valves which are screwed directly into the exhaust connections of valves.

Note:
The regulating spindle of this valve can be unscrewed right out of the valve.
Therefore the spindle must not be unscrewed more than 8 turns from the closed position and must then be secured immediately with the lock nut.

Dimension table and order instructions

Order Instructions		A	B	C	D	E	SW	SW1	Weight Mass (kg)
Type	Order No.								
DVE-06	KY 6952	G1/8	14	24	5.0	4	14	9	0.015
DVE-08	KY 6953	G1/4	18	32	7.5	6	17	11	0.030
DVE-15	KY 6954	G1/2	27	45	9.5	10	27	17	0.098

Material: Brass/sintered bronze



Dimensions in mm

Contents

Description	Page
Dual-pressure valve (AND)	32
OR valve (OR)	33
Timer	34, 35
2/2 way screw-in valves	36, 37
Miniature screw-in pressure regulators	38, 39
Relief valves	40

Special valves

- *Logic components AND/OR*
- *Timer*
- *2/2 way screw-in valves*
- *Miniature screw-in pressure regulators*
- *Relief valves*



AND valves (dual pressure valves) G1/8

In-line version

Series AND 8

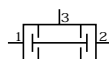
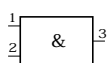

Actuation: Pneumatic

Characteristics			Pressures quoted as gauge pressure	
Characteristics	Symbol	Unit	Description	
General features				
Type			Poppet valve	
Mounting			2 through-bolts M5	
Tube connection			Thread	
Port size			G1/8	
Weight (mass)		kg	0.05	
Installation			In any position	
Ambient temperature range	T_{min} T_{max}	°C	-20 +80	Note: When using below freezing point (0 °C) it is necessary to consult us
Medium temperature range	T_{min} T_{max}	°C	0 +80	
Medium			Filtered compressed air	
Lubrication			With or without oil mist lubrication	
Pneumatic characteristics				
Nominal pressure	p_n	bar	6	
Operating pressure range	p_{min}	bar	0.5	
	p_{max}	bar	10	
Nominal flow	Q_N	l/min	134	

Dimensions

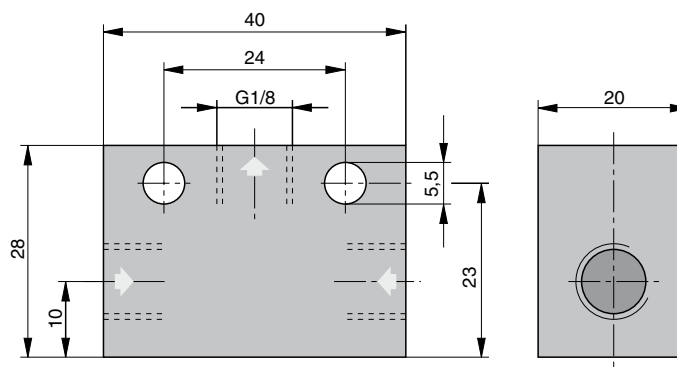

Order Instructions

AND 8-1/8 PA10207

Dimensions in mm

Characteristics			Pressures quoted as gauge pressure	
Characteristics	Symbol	Unit	Description	
General features				
Type	Poppet valve			
Mounting	2 through-bolts M5			
Tube connection	Thread			
Port size			G1/8	G1/4
Weight (mass)		kg	0.05	0.07
Installation	In any position			
Ambient temperature range	T_{min}	°C	-20	Note: When using below freezing point (0 °C) it is necessary to consult us
	T_{max}	°C	+80	
Medium temperature range	T_{min}	°C	0	
	T_{max}	°C	+80	
Medium	Filtered compressed air			
Lubrication	With or without oil mist lubrication			
Pneumatic characteristics				
Nominal pressure	p_n	bar	6	
Operating pressure range	p_{min}	bar	0.5	
	p_{max}	bar	10	
Nominal flow	Q_N	l/min	385	635

OR valves (shuttle valves) G1/8, G1/4

In-line version

Series OR 8

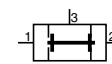
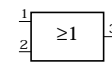

Dimensions

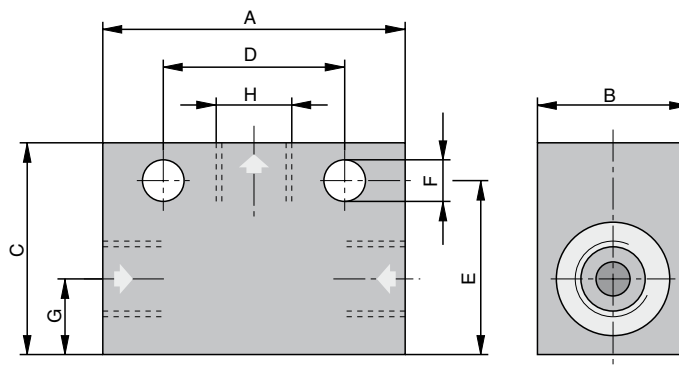

Dimension table and order instructions

Order Instructions		A	B	C	D	E	F	G	H
Type	Order No.								
OR 8-1/8	PA10206	40	20	28	24	23	5.5	10	G1/8
OR 8-1/4	PA12516	45	20	35	24	27	5.5	10	G1/4

Dimensions in mm



Timer

In-line version

Series T3P10



Versions:

- normally closed (NC)
- normally open (NO)

Delivery includes:

- Timer without base plate
- please order this separately

Characteristics			Pressures quoted as gauge pressure
Characteristics	Symbol	Unit	Description
General features			
Mounting		On base plate	
Tube connection		Swivelling plug-in connection	
Port size		mm	For tube Ø 4/2.7
Installation		In any position	
Ambient temperature range		T_{min}	°C -5
		T_{max}	°C +50
Medium		Filtered and lubricated or filtered and unlubricated air	
Pneumatic characteristics			
Nominal pressure	p_n	bar	6
Operating pressure range		p_{min}	bar 2
		p_{max}	bar 8
Nominal flow	Q_N	l/min	170
Time delay	t_{max}	s	max. 60 (according to type)
Min. reset time		s	< 0.1

Dimensions

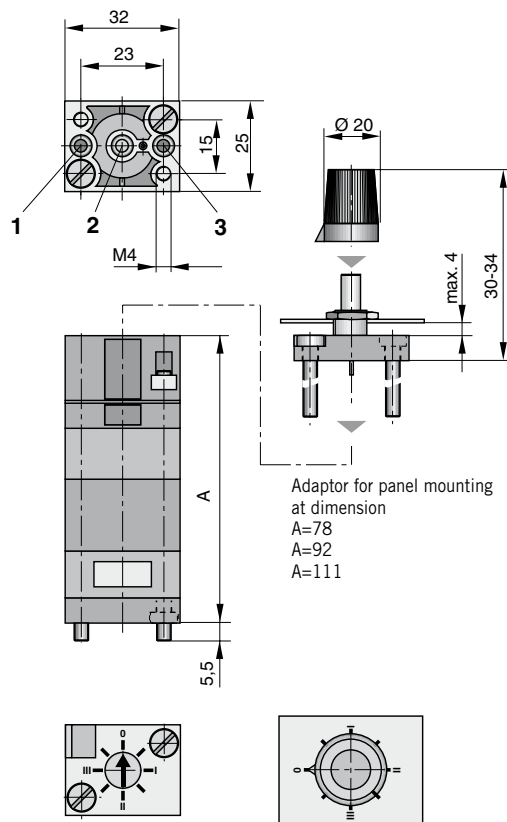

Dimension table, time delay and weight

Type	Time delay (s)	Dim. A	Weight (mass) kg
T3P10-NG-15	0.1 – 15	78	0.090
T3P10-NG-30	0.1 – 30	92	0.100
T3P10-NG-60	0.1 – 60	111	0.120
T3P10-NO-15	0.1 – 15	78	0.090
T3P10-NO-30	0.1 – 30	92	0.100

Order Instructions

Time delay (s)	Function	Order Instructions Type	Order No.
0.1 – 15	NC *	T3P10-NG-15	KL8255
0.1 – 30	NC *	T3P10-NG-30	KL8256
0.1 – 60	NC *	T3P10-NG-60	KL8257
0.1 – 15	NO *	T3P10-NO-15	KL8258
0.1 – 30	NO *	T3P10-NO-30	KL8259
Adaptor for panel mounting at dim. A=78			KL8260
Adaptor for panel mounting at dim. A=92			KL8261
Adaptor for panel mounting at dim. A=111			KL8262

* NC = normally closed
NO = normally open

Dimensions in mm

Single base plate – bolt mounting version – Type EAP-S

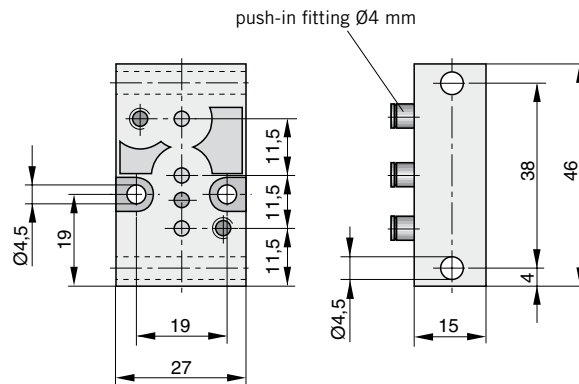

Base plate for timer

- Versions:**
 – Bolt mounting
 – Rail mounting

Single base plate – rail mounting version – Type EAP-H

Characteristics

Characteristics	Description
Mounting	On rail to EN 50022 (35 x 15 or 35 x 7,5)
Connections	Swivelling plug-in connection for tube $\varnothing 4/2.7$

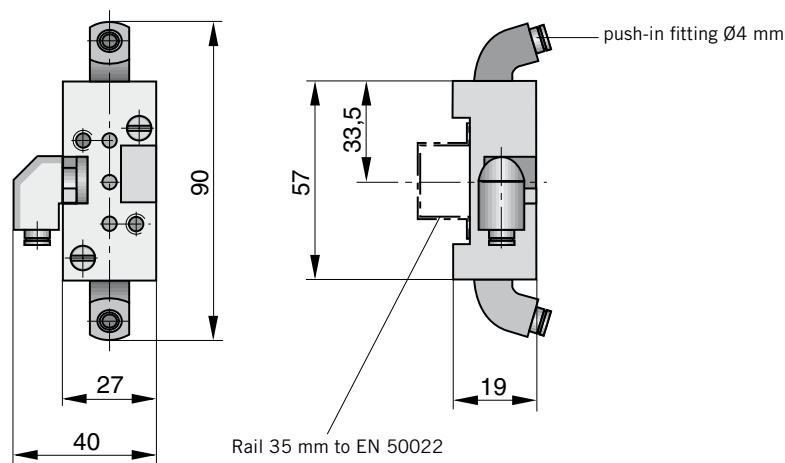

Colour coding

Connection	Colour	Tube connection
1	green	Input 1
2	red	Output 3
3	yellow	Input or air supply 2

Order Instructions

Benennung	Order Instructions	
	Type	Order No.
Single base plate, bolt mounting version	EAP-S	KL8266
Single base plate, rail mounting version	EAP-H	KL8267

Dimensions in mm



2/2 way screw-in valves (check valves) G1/8 – G1/2

Series EVP

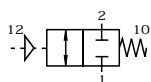

Actuation: pneumatic

Characteristics			Pressures quoted as gauge pressure	
Characteristics	Symbol	Unit	Description	
General features				
Type	Spool valve with spring return			
Tube connection	Port 1: Internal thread to ISO 228 Port 2: External thread to ISO 228 Port 12: G1/8 internal, push-in. Ø 4			
Port size	See dimension drawing			
Weight (mass)	kg	See table		
Installation	In any position – rings can be rotated 360° after the valve has been installed			
Ambient temperature range	T_{min} T_{max}	°C	-10 +70	Note: When using below freezing point (0 °C) it is necessary to consult us
Medium temperature range	T_{min} T_{max}	°C	-10 +70	
Medium	Filtered compressed air, neutrale Gase *			
Lubrication	With or without oil mist lubrication ¹⁾			
Material	Metal parts: Nickel-plated brass or stainless steel Springs: Stainless steel Seals: Buna N			
Pneumatic characteristics				
Nominal pressure	p_n	bar	6	
Operating pressure range	p_{min}	bar	0	
	p_{max}	bar	10	
Nominal flow	Q_N	l/min	See table	
Actuation				
Pneumatic				Direct
Actuation pressure range	p_{st}	bar	See diagram	

* Other media on request

¹⁾ we recommend the use of mineral oil VG 32 to ISO 3448



Nominal flow, tightening torque, opening pressure, weight (mass)

Port size	DN [mm]	Q_N [l/min]	max. tightening [Nm]	Weight Mass [kg]
G1/8	4.0	300	3.0	0.068 – with thread
				0.070 – push-in fitting Ø 6
G1/4	5.6	700	7.0	0.104 – with thread
				0.104 – push-in fitting Ø 6
				0.110 – push-in fitting Ø 8
G3/8	7.7	1200	9.0	0.150 – with thread
				0.145 – push-in fitting Ø 8
				0.155 – push-in fitting Ø 10
G1/2	10.0	2100	15.0	0.210 – with thread
				0.240 – push-in fitting Ø 12

Dimensions in mm

Pilot pressure in relation to operating pressure

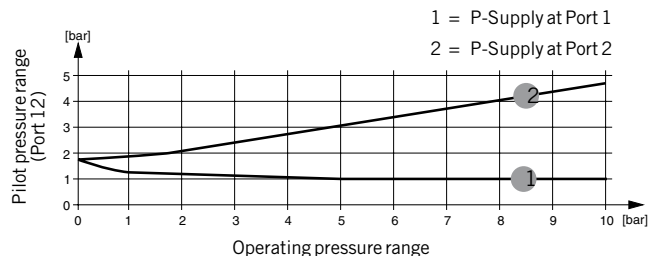

Example

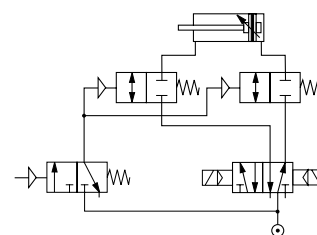

The cylinder can be stopped during extension and retraction

2/2 way screw-in valves (check valves) G1/8 – G1/2

Series EVP

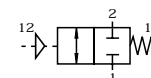

Actuation: pneumatic

Dimensions

Dimensions with internal thread

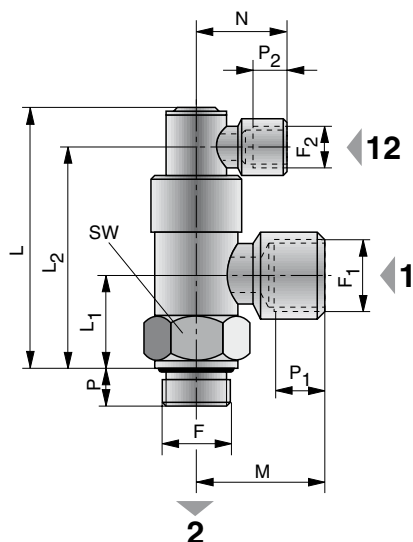

Dimensions with push-in fitting

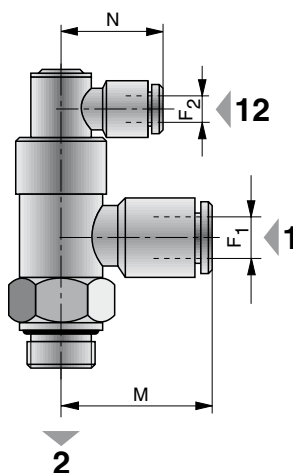

Dimension table and order instructions

F	F ₁	F ₂	L	L ₁	L ₂	M	N	P	P ₁	P ₂	SW	Order Instructions Type	Order No.
G1/8	G1/8	G1/8	51.5	16.0	42.0	21.0	21	6	7	7	14	EVP-1/8	KL4062
G1/8	∅ 6	∅ 4	51.5	16.0	42.0	25.0	25	6	-	-	14	EVP-1/8	KL4063
G1/4	G1/4	G1/8	57.5	19.5	48.0	25.0	21	8	8	7	17	EVP-1/4	KL4064
G1/4	∅ 6	∅ 4	57.5	19.5	48.0	27.5	25	8	-	-	17	EVP-1/4	KL4065
G1/4	∅ 8	∅ 4	57.5	19.5	48.0	32.0	25	8	-	-	17	EVP-1/4	KL4066
G3/8	G3/8	G1/8	63.0	22.5	53.5	31.0	21	8	10	7	22	EVP-3/8	KL4067
G3/8	∅ 8	∅ 4	63.0	22.5	53.5	31.5	25	8	-	-	22	EVP-3/8	KL4068
G3/8	∅ 10	∅ 4	63.0	22.5	53.5	36.0	25	8	-	-	22	EVP-3/8	KL4069
G1/2	G1/2	G1/8	71.5	27.0	61.5	40.0	21	12	14	7	27	EVP-1/2	KL4070
G1/2	∅ 12	∅ 4	71.5	27.0	61.5	40.5	25	12	-	-	27	EVP-1/2	KL4071

Dimensions in mm



Miniature screw-in pressure regulators G1/8, M5

Series HMR, HMRS

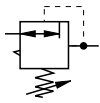

Versions:

- Screw-in version
- for panel mounting
- Viton version*

* Note:
The Viton version can be used for temperatures up to 140°C.
Please consult us before using the valve in high temperatures, especially when using other media than compressed air.



Characteristics			Pressures quoted as gauge pressure	
Characteristics	Symbol	Unit	Description	
General features				
Type	Pressure regulating valve, piston type with secondary pressure relief			
Tube connection	Thread			
Port size	Input: G1/8 and M5 Output: M5 Gauge: M5			
Nominal bore	mm	2.2		
Weight (mass)	kg	0.08 (0.11)		
Installation	In any position			
Ambient temperature range	T_{min} T_{max}	°C	-20 +60	Note: When using below freezing point (0 °C) it is necessary to consult us
Medium temperature range	T_{min} T_{max}	°C	-20 +80	
Medium	Filtered compressed air, neutral gases*			
Lubrication	With or without oil mist lubrication ¹⁾			
Material	Metal parts: Brass Ms 58 Springs: Stainless and zinc-plated steel Seals: Buna N			
Pneumatic characteristics				
Operating pressure range	p_{min}	bar	0	
	p_{max}	bar	12	
Secondary pressure range	p_{min}	bar	1	
	p_{max}	bar	8	
Flow rate	Q_N	l/min	100 **	

* Other media on request

** at $p_1 = 10$ bar to $p_2 = 6$ bar, $\Delta p = 1$ bar

¹⁾ We recommend the use of mineral oil type VG32 to ISO 3448

Dimensions in mm

Dimensions

Screw-in version

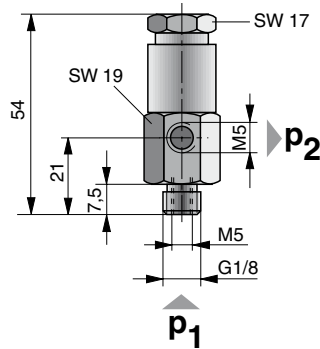

Panel mounting version

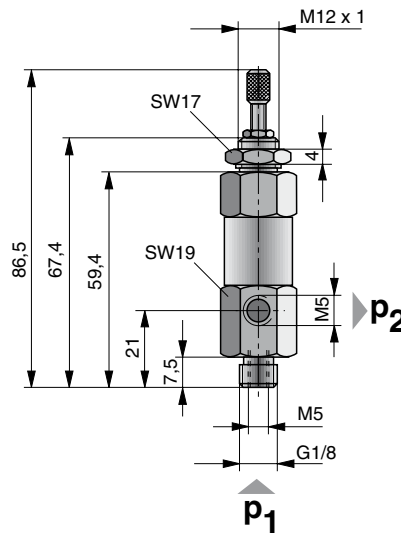

Miniature screw-in pressure regulators G1/8, M5

Series HMR, HMRS

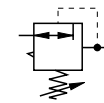

- Versions:**
- Screw-in version
 - for panel mounting
 - Viton version*

Order Instructions

Version	Port size	Sealing material	Order Instructions	
			Type	Order No.
Screw-in version	G1/8, M5	Buna N	HMR-1/8	KL4072
Panel version	G1/8, M5	Buna N	HMRS-1/8	KL4074
Screw-in version	G1/8, M5	Viton	HMR-1/8-V	KL4073
Panel version	G1/8, M5	Viton	HMRS-1/8-V	KL4075

* Note:
The Viton version can be used for temperatures up to 140°C.
Please consult us before using the valve in high temperatures, especially when using other media than compressed air.

Dimensions in mm



Relief Valves G1/8, G1/4

Screw-in version

Series USV

Adjustment:

1.1 – 3 bar
3.1 – 6 bar

Characteristics		Pressures quoted as gauge pressure	
Characteristics	Symbol	Unit	Description
General features			
Type	Spring-loaded poppet valve with adjustable opening pressure		
Type		USV-1/8	USV-1/4
Port size		G1/8	G1/4
Weight (mass)	kg	0.031	0.034
Installation			
In any position			
Temperature range	T_{\min}	°C	-10
	T_{\max}	°C	+90
Medium			
Compressed air			
Opening pressure	bar	1.1 – 3 or 3.1 – 6 (adjustable)	
Material			
Brass			

Dimensions

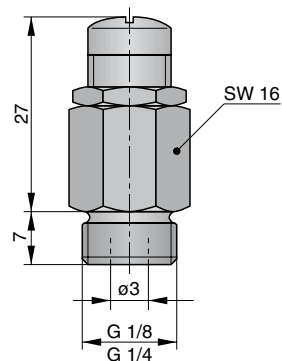

Order Instructions

Adjustment	Port size	Order Instructions	
		Type	Order No.
1.1 – 3 bar	G1/8	USV-1/8	KY 4093
3.1 – 6 bar	G1/8	USV-1/8	KY 4065
1.1 – 3 bar	G1/4	USV-1/4	KY 4094
3.1 – 6 bar	G1/4	USV-1/4	KY 4066



Dimensions in mm

Contents

Description	Page
Exhaust silencers, sintered metal	42
Exhaust silencers, plastic	43
Strainers, brass	44, 45
Screw-in sieves, brass	46, 47

Exhaust silencers, strainers, screw-in sieves

- *Exhaust silencers, sintered metal*
- *Exhaust silencers, plastic*
- *Strainers, brass*
- *Screw-In sieves, brass*



Exhaust silencers M5 – G1

Exhaust silencers

Series D1, D1K

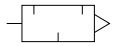

Exhaust silencers disperse the exhaust air, reduce exhaust noise and prevent the ingress of dirt into components

Characteristics		Pressures quoted as gauge pressure							
Characteristics	Symbol	Unit	Description						
General features									
Type	Single-chamber principle								
Port size	M5	G1/8	G1/4	G3/8	G1/2	G3/4	G1		
Weight (mass)									
– Type D1	kg	0.002	0.07	0.013	0.032	0.067	0.121	0.209	
– Type D1I	–	–	0.013	–	–	–	–	–	
– Type D1K	kg	–	0.003	0.007	0.009	–	–	–	
Ambient temperature range	T_{max}	°C	+250 (danger of icing in lower temperature range)						
Material	Sintered bronze (on M5, threaded part is bronze)								
Grain size	mm	0.3 to 0.6							
Pneumatic characteristics									
Operating pressure range	p_{min}	bar	0						
	p_{max}	bar	16						

Dimensions Type: 50030
Port size M5

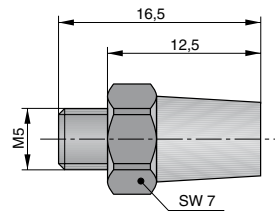

Dimensions Type: D1
Port size G1/8–G1

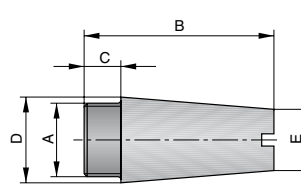

Dimensions Type: D1K
Port size G1/8–G3/8

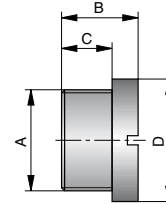

Order Instructions: KY8869

Dimension table and order instructions

A	B	C	D	E	Order Instructions	
					Type	Order No.
G1/8 i	22	8	Ø 15	Ø 12	D1-06I	PD 20636
G1/8	21	6	Ø 11	Ø 8	D1-06	KY 2010
G1/8	10	6	Ø 12	–	D1K-06	KY 2260
G1/4	27	8	Ø 14	Ø 10	D1-08	KY 2011
G1/4	12	8	Ø 15	–	D1K-08	KW 0705
G3/8	38	8	Ø 18	Ø 15	D1-10	KY 2012
G3/8	12	8	Ø 20	–	D1K-10	KW 0706
G1/2	44	10	Ø 24	Ø 19	D1-15	KY 2013
G3/4	63	12	Ø 30	Ø 20	D1-20	KY 2014
G1	77	15	Ø 36	Ø 25	D1-25	KY 2015



Dimensions in mm

Characteristics

Pressures quoted as gauge pressure

Characteristics	Symbol	Unit	Description
General features			
Type			Single-chamber principle
Port size			G1/8 G1/4 G3/8 G1/2 G3/4 G1
Ambient temperature range	T_{min}	°C	-30
	T_{max}	°C	+80
Material			Polyethylen
Grain size		mm	0.3 – 0.6
Medium			Highly resistant to most media, but not to chlorinated hydrocarbons (trichloroethylene, perchloroethylene or hydrogen tetrachlorides)
Pneumatic characteristics			
Operating pressure range	p_{min}	bar	0
	p_{max}	bar	8

Exhaust silencers M5 – G1

Exhaust silencers

Series D1-..K

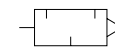

Exhaust silencers disperse the exhaust air, reduce exhaust noise and prevent the ingress of dirt into components

These exhaust silencers are recommended for use in environments where particle deposition might block the pores of sintered bronze silencers, e.g. in the cement and concrete industry

Noise reduction for a G1/2 valve with exhaust silencer and $p = 6$ bar

Dimensions Type: D1....K Port size G1/8 – G1

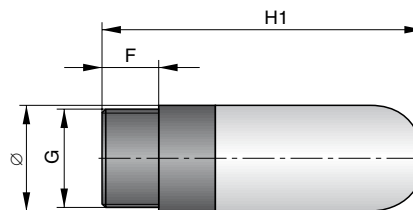
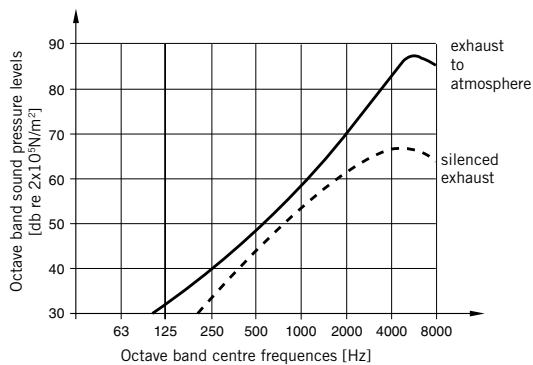

Dimension table and order instructions

G	Ø	F	H1	Order Instructions	
				Type	Order No.
M5	6.7	3.4	20.4	D1-M5K	KY8830
G1/8	12.7	6.7	34	D1-06K	KY8831
G1/4	15.5	8.2	42.5	D1-08K	KY8832
G3/8	18.4	12.1	67.5	D1-10K	KY8833
G1/2	23	14	78	D1-15K	KY8834
G3/4	38.9	14.9	131	D1-20K	KY8835
G1	49.4	20	160	D1-25K	KY8836

Dimensions in mm



Strainers for tubings G1/4 – G2

Series SFS

For direct installation
in tubings

Characteristics		Pressures quoted as gauge pressure		
Characteristics	Symbol	Unit	Description	
General features				
Type	Filter element for solid particles			
Port size			G1/4	G3/8 G1/2
Weight (mass)	kg	0.170	0.155	0.165
Pore size	µm	45		
Installation				
horizontal, sieve facing dows				
Medium and ambient temperature	T _{min} T _{max}	°C	0 +150	
Material				
Brass (Filter element: sinter bronze)				
Pneumatic characteristics				
Operating pressure range	p _{min} p _{max}	bar	-1 +16	
Nominal flow ¹⁾	Q _N	l/min	1700	3700 7500
Recommended flow ¹⁾	Q	l/min	783	1320 2570

¹⁾ at 6 bar and $\Delta p = 0,2$ bar

Dimensions

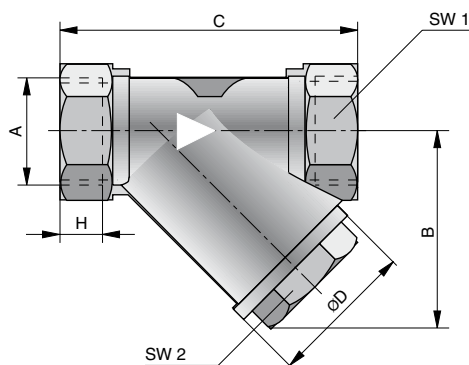

Operating principle:
When air flows through the filter element, any large particles are retained. The pore size for the sinter-bronze filter element is 45 µm

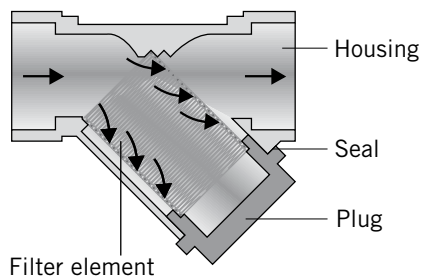

Dimensions in mm

Strainers for tubings G1/4 – G2

Series SFS

For direct installation
in tubings

	G3/4	G1	G1 1/4	G1 1/2	G2
	0.285	0.460	0.690	1.010	1.535
12000		on request	on request	on request	on request
3670					

Dimension table

Dimension	Port size (A)								
	G1/8	G1/4	G3/8	G1/2	G3/4	G1	G1 1/4	G1 1/2	G2
ØD	8	8	10	15	20	25	32	40	50
B	40	40	40	40	50	60	68	75	90
C	55	55	55	58	70	90	96	106	126
H	10.0	10.0	10.3	10.5	12.0	17.0	17.5	17.5	20
SW 1	21	21	21	25	31	38	49	55	68
SW 2	20	20	20	20	27	32	35	38	46

Order instructions

Port size	Strainers with sinter bronze filter element		Spare parts Sinter element (45 µm)	
	Type	Order No.	Type	Order No.
G1/4	SFS-1/4	KL 2001	SFSE-1/4	KL 2015
G3/8	SFS-3/8	KL 2002	SFSE-3/8	KL 2015
G1/2	SFS-1/2	KL 2003	SFSE-1/2	KL 2015
G3/4	SFS-3/4	KL 2004	SFSE-3/4	KL 2016
G1	SFS-1	KL 2005	SFSE-1	KL 2017
G1 1/4	SFS-1 1/4	KL 2006	SFSE-1 1/4	KL 2018
G1 1/2	SFS-1 1/2	KL 2008	SFSE-1 1/2	KL 2019
G2	SFS-2	KL 2008	SFSE-2	KL 2020



Dimensions in mm

Screw-in sieve M5 – G1/4

Series SB-..G

Lathed version with fitted sieve

Material:

Housing: brass

Sieve: stainless steel, brass

Mesh dimension:

100 - 450 μ m

Dimensions

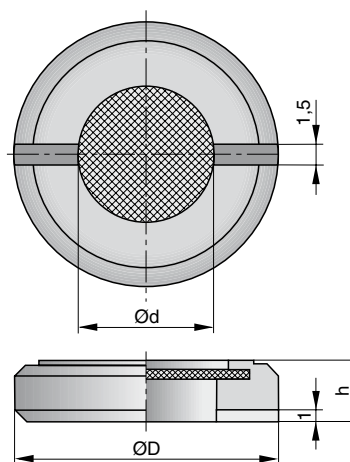

Dimension table and order instructions

$\varnothing D$ suitable for port size	$\varnothing d$	h	Order Instructions	
			Type	Order No.
M5	2	3	SB-M5-G	KY2330
G1/8	5	5	SB-1/8-G	KY2008
G1/4	8	5	SB-1/4-G	KY2007



Dimensions in mm

Dimensions

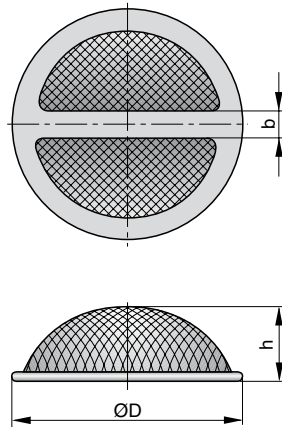

Screw-in sieve G1/4 – G1/2

Series SB

Plate version with flanged sieve

Material:

Housing: brass plate

Sieve: stainless steel, brass

Mesh dimension:

100 - 450 μ m

Dimension table and order instructions

ØD suitable for port size	b	h	Order Instructions	
			Type	Order No.
G1/4	2.5	7	SB-14	KW0723
G3/8	2.5	9	SB-38	KY2097
G1/2	2.5	11	SB-12	KY2098

Dimensions in mm



Contents

Description	Page
Pressure switches, pneumatic, with plug	50
Pressure switches, pneumatic, with flat pins	51
Pressure switches, pneumatic – with internal thread – with flange connection	52–55
Pressure switches, electronic	56, 57

Pressure Switches

- *Pressure switches, pneumatic*
- *Pressure switches, electronic*



Pressure Switches G1/8, G1/4

– Pressure switch pneumatic

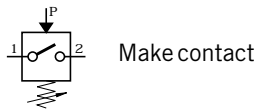
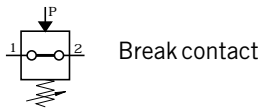

Switching function:

- Make contact
 - closes the circuit when the set pressure is reached
- Break contact
 - interrupts the circuit when the set pressure is reached



Characteristics

Pressures quoted as gauge pressure

Characteristics	Symbol	Unit	Description
Type			Break contact or make contact – see table at the bottom
Setting range	$p_{\min/\max}$	bar	See table at the bottom
Safety pressure relief	p_{\max}	bar	300
Port size			G1/8, G1/4
Weight (mass)		kg	0.090
Material			
– Housing			Passivated steel
– Diaphragm			Buna N
Medium and ambient temperature range	T_{\max}	°C	+100
Switch back difference		%	Max. 5 – 15
Voltage	U	V	Max. 48
Current	I	A	0.5
Electrical connection			Plug contacts, plug
Degree of protection		IP	65 with plug
Switching frequency		s/min	Max. 200

Dimensions

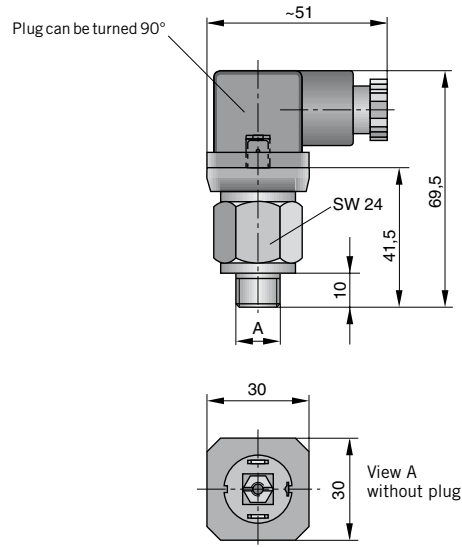

Dimensions and order instructions

Order Instructions		Port size	Function	Setting range [bar]
Type	Order No.	A		
PR / 0.1-1 NC ST 1/4 48	KL3439	G1/4	Break contact	0.1-1
PR / 0.1-1 NO ST 1/4 48	KL3440	G1/4	Make contact	0.1-1
PR / 1-10 NC ST 1/8 48	KL3437	G1/8	Break contact	1-10
PR / 1-10 NC ST 1/4 48	KL3436	G1/4	Break contact	1-10
PR / 1-10 NO ST 1/8 48	KL3438	G1/8	Make contact	1-10
PR / 1-10 NO ST 1/4 48	KL3435	G1/4	Make contact	1-10

Dimensions in mm

Characteristics

Pressures quoted as gauge pressure

Characteristics	Symbol	Unit	Description
Type			Break contact oder Make contact – see table at the bottom
Setting range	$p_{\min/\max}$	bar	See table at the bottom
Safety pressure relief	p_{\max}	bar	300
Port size			G1/8, G1/4
Weight (mass)		kg	0.075
Material			
– Housing			Passivated steel
– Diaphragm			Buna N
Mediums- und Ambient temperature range	T_{\max}	°C	+100
Switch back difference		%	Max. 5 – 15
Voltage	U	V	Max. 48
Current	I	A	0.5
Electrical connection			Flat pin plug, protective cap
Degree of protection		IP	65 with protective cap
Switching frequency		s/min	200

Dimensions

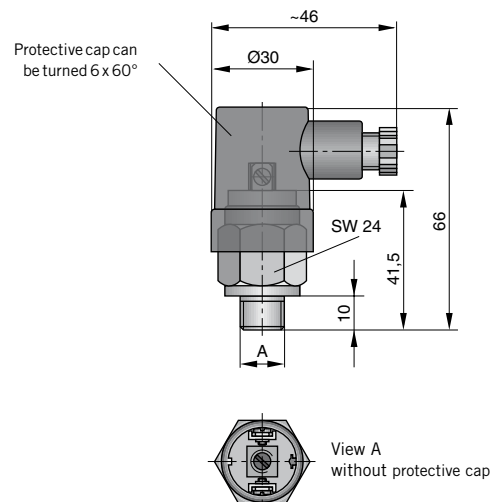

Dimensions and order instructions

Order Instructions	Order No.	Port size A	Function	Setting range [bar]
PR / 0.2-1 NO SR 1/4 48	KL3445	G1/4	Make contact	0.2-1
PR / 0.1-1 NC SR 1/4 48	KL3454	G1/4	Break contact	0.1-1
PR / 0.1-1 NO SR 1/4 48	KL3455	G1/4	Make contact	0.1-1
PR / 1-10 NC SR 1/8 48	KL3452	G1/8	Break contact	1-10
PR / 1-10 NC SR 1/4 48	KL3451	G1/4	Break contact	1-10
PR / 1-10 NO SR 1/8 48	KL3453	G1/8	Make contact	1-10
PR / 1-10 NO SR 1/4 48	KL3450	G1/4	Make contact	1-10

Dimensions in mm

Pressure Switches G1/8, G1/4

– Pressure switch pneumatic

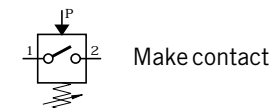
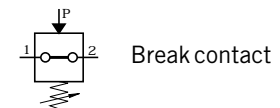

Switching function:

- Make contact
 - closes the circuit when the set pressure is reached
- Break contact
 - interrupts the circuit when the set pressure is reached



Pressure Switches G1/8, G1/4

Series G1/4-..I
Series G1/4-..P

Characteristics

Actuation: Pneumatic

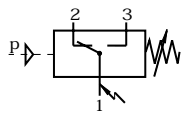

Features

- suited for intrinsically safe operation
- especially compact design
- high switching frequency
- attractive design
- Shockproof up to 30 g

Pin 1 – 3:

rising pressure makes contact

Pin 1 – 2:

rising pressure breaks contact

Delivery includes:

The flange version (surface roughness of flange surface 12µm) is supplied with an O-ring 5 x 1.5mm and 2 screws 5 x 35 DIN 912. Minimum thread length to be used: 4 mm.

Max. diameter of the pressure opening 3 mm.



Characteristics

Pressures quoted as gauge pressure

Characteristics	Symbol	Unit	Description
Type – thread version			G1/4-0I* G1/4-2I G1/4-8I G1/4-16I
Type – lange version			G1/4-0P* G1/4-2P G1/4-8P G1/4-16P
Setting range	$p_{\min/\max}$	bar	-1 to 0 0.2-2 0.5-8 1-16
Safety pressure relief	p_{\max}	bar	80 80 80 80
Port size			Type I: G1/4 internal thread, Type P: flange
Mounting			2 through-holes Ø 5.2
Installation			In any position
Weight (mass)		kg	0.275
Medium			Filtered compressed air (10µm), lubricated or unlubricated
Material			
Housing			Special aluminium die casting, powder-coated
Diaphragm, Seals			Buna N
Medium and ambient temperature range	T_{\min} T_{\max}	°C	-10 +80
Consistency		%	±2 in relation to end-of-range value
Switch back difference			See diagram
Hysteresis, vacuum version		%	<15
Vibration resistance		g	10 (10 ... 2000 Hz)
Shock resistance		g	30
Voltage	U	V	Max. 250
Voltage type			AC and DC
Operating current and operating voltage for category of use			AC12 to VDE0660 4A at 250 VAC AC14 to VDE0660 1A at 250 VAC DC12 to VDE0660 3A at 28 VDC DC13 to VDE0660 1A at 28 VDC
CE marking			To EC Directive 73/23/EWG
Electrical connection			Plug to DIN EN 175301-803, Form A, ISO4400 or M12x1 – 4-pin
Degree of protection		IP	65
Switching element			Pole-changing switch with catch spring as switching element, with self-cleaning contacts
Switching frequency		s/min	Max. 200

* for vacuum operation

Selection and Mounting Notes

Range selection:

Selection is optimal when the switching points are in the middle of the switching range.

Electrical connection:

Wiring according to VDE regulations.

Tightening torque for plug: 0.7 ± 0.1 Nm

Outdoor use only with sufficient protection against

critical environmental conditions (e.g. aggressive atmosphere, salty environments, high temperature changes).

Switch back difference

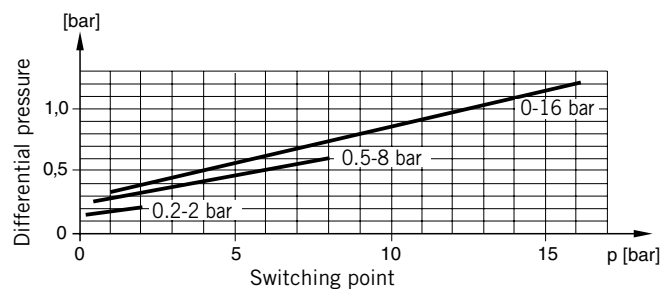

Dimensions – Version with internal thread and plug

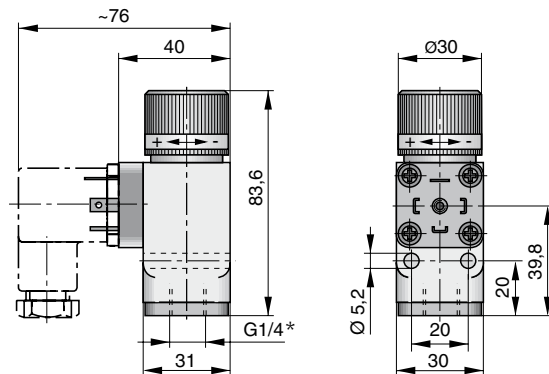

* Thread: 11 mm deep

Pressure Switches G1/8, G1/4

Series G1/4-..I

Dimensions
Order Instructions

Version:
With internal thread

Dimensions – Version with internal thread and connector M12x1)

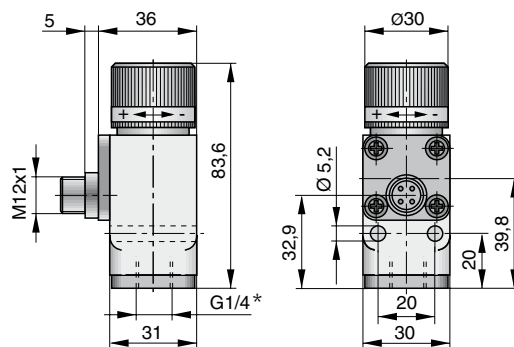

* Thread: 11 mm deep

Order instructions

Setting range [bar]	Order Instructions	
	Type	Order No.
-1 to 0	G1/4-0I-DIN	KL3200
-1 to 0	G1/4-0I-M12	KL3208
0.2 to 2	G1/4-2I-DIN	KL3201
0.2 to 2	G1/4-2I-M12	KL3209
0.5 to 8	G1/4-8I-DIN	KL3202
0.5 to 8	G1/4-8I-M12	KL3210
1.0 to 16	G1/4-16I-DIN	KL3203
1.0 to 16	G1/4-16I-M12	KL3211

Dimensions in mm



Pressure Switches G1/8, G1/4

Series G1/4-..P

Dimensions
Order Instructions

Version:
Flange version

Dimensions – Flange version with plug

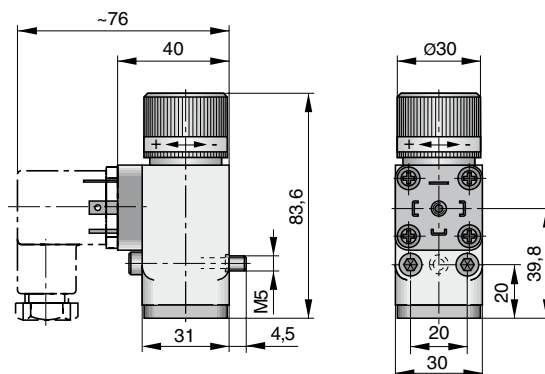

Dimensions – Flange Version with connector M12x1

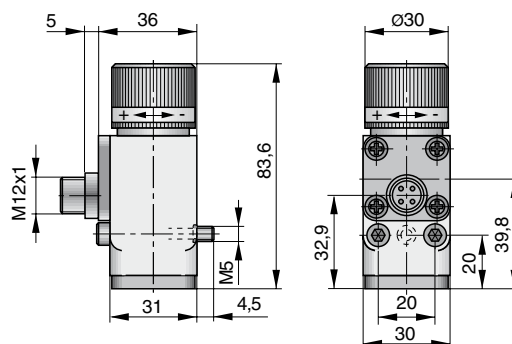

Order instructions

Setting range [bar]	Order Instructions	
	Type	Order No.
-1 to 0	G1/4-0P-DIN	KL3204
-1 to 0	G1/4-0P-M12	KL3212
0,2 to 2	G1/4-2P-DIN	KL3205
0,2 to 2	G1/4-2P-M12	KL3213
0,5 to 8	G1/4-8P-DIN	KL3206
0,5 to 8	G1/4-8P-M12	KL3214
1,0 to 16	G1/4-16P-DIN	KL3207
1,0 to 16	G1/4-16P-M12	KL3215

Dimensions in mm

Plugs to DIN EN 175301-803, Form A, ISO 4400

Standard version



Version with LEDs



**Pressure
Switches
G1/8, G1/4**

*Accessories
– Plugs*

Plugs to DIN EN 175301-803, Form A, ISO 4400

Description	Type	Order No.
Standard version	GSD-30DS	KL3349
Version with LEDs 24V	GSD-30DSL24V	KL3350
Version with LEDs 230V	GSD-30DSL230V	KL3351

Dimensions in mm



Pressure switches Electronic

Series EDP

Actuation: Electrical

Version:

- with flange connection
- with thread on request

The Type EDP electronically actuated pressure switches are used to convert pneumatic signals into electrical signals.

The pressure range 0-16 bar can be adjusted individually, in either bar or psi.

The pressure switches can be used as threshold value comparators with one hysteresis or as window comparators with two hystereses.

A robust ceramic measuring cell acts as a measured value transducer.

Features:

- simple, menu-driven programming via 3 membrane keys
- 3-digit red LED display (pressure gauge function)
- electronic locking
- versions for specific applications on request

Applications

- Pneumatic control systems
- Pressing technology
- Welding technology
- Packing machines and filling systems
- Test systems
- Clamping systems
- Plastic blow-moulding machinery
- Robotics and handling industry



Characteristics

Pressures quoted as gauge pressure

Characteristic	Symbol	Unit	Description
Type – flange version			EDP-V EDP
Setting range	$p_{\min/\max}$	bar	-1 to 0 0-16
Safety pressure relief	p_{\max}	bar	100 100
Port size			Flange connection (see dimension drawing)
Display			3 digit, red 7-Segment LED-Display, programmable 0°/180°
Display for operating status			LED red/green
Linearity		%	$< \pm 0.2$ to $1.5 p_N$
TK zero point		%	$< \pm 0.2 p_N$
Installation			In any position
Material			
– Housing			PA, part in contact with medium: Al
– Measuring cell			Ceramic
– Seals			Buna N, part in contact with medium: FKM
Weight (mass)		kg	0.100
Medium			Filtered compressed air, lubricated or unlubricated, weakly acidic or weakly alkaline fluids
Ambient temperature range	T_{\min} T_{\max}	°C °C	-20 +70
Medium temperature range	T_{\min} T_{\max}	°C °C	-20 +70
Voltage	U	V	18 – 32
Voltage Type			Direct current
Power consumption		mA	< 80 without switching outlet
Switching current		A	SP1 max. 1.3 (PIN4) SP2 / ERROR max. 0.3 (PIN2)
Switching logic			NO / NC programmable
Switching outlet			Short circuit-proof
Electrical connection			Plug M12x1
Degree of protection		IP	67 to EN 60529

Symbol



Connection diagram

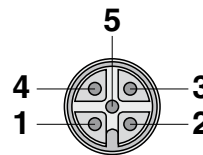

Electrical connection

- 1 = bn (brown) +Uc
- 2 = ws (white) SP2
- 3 = bl (blue) GND
- 4 = sw (black) SP1

Threshold value comparator / window value comparator functions

Threshold value comparator with hysteresis

Window comparator with 2 hystereses

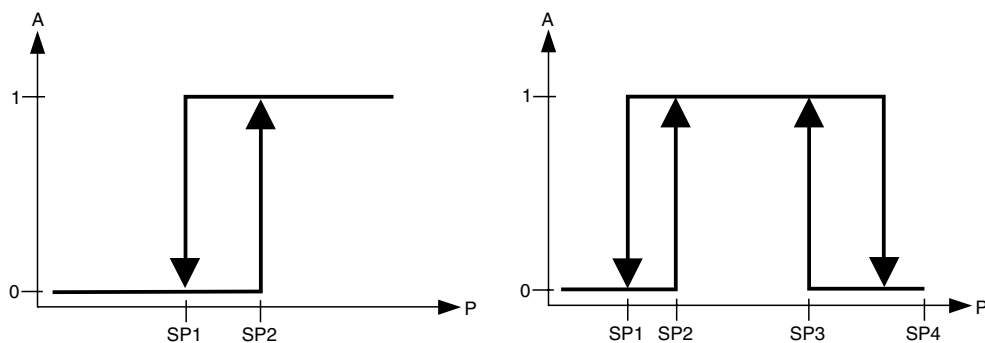

The illustrations show the NO (normally open) presetting. For the NC (normally closed) presetting, the diagrams are horizontally mirror-imaged, so that the start value is at 1.

Dimensions – Flange version with M12x1connector

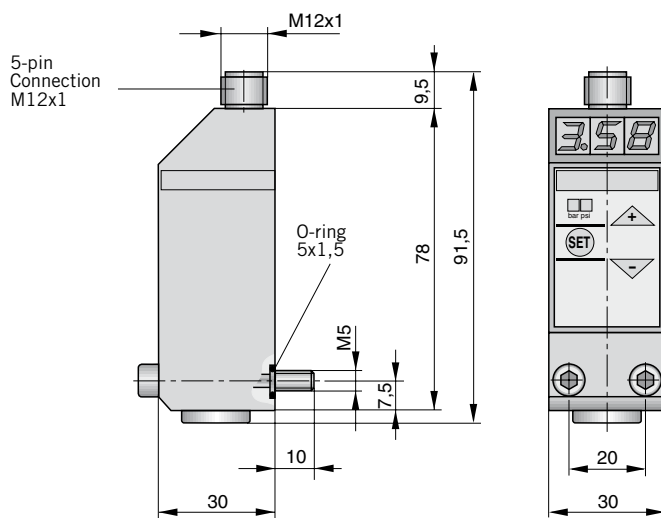

Order Instructions

Setting range [bar]	Order Instructions	Order No.
-1 to 1	EDP-V	KL3385
0 to 16	EDP	KL3384

Dimensions in mm



Contents

Description	Page
Characteristics	60
Straight adaptors	61
Elbow adaptors	62, 63
Banjo elbow adaptors	63, 65
Run tee and branch tee adaptors	64, 65
Connectors	66-68

Fittings and accessories

– *Metal push-in fittings*



Fittings and accessories

Metal push-in fittings

Connection system for fast assembly / dismantling without tools

- Metal fittings (nickel-plated brass)
- Tubing clamped on outside diameter by precision collet
- Tubing sealed on outside diameter by O-rings
- Integrated O-rings (on types with parallel thread) for reliable thread sealing (e.g. on bevelled or uneven surfaces) and easier handling (no additional seal rings required)
- Connecting the tubing: simply push the tube into the collet up to the stop
- Disconnecting the tubing: push the release ring back and pull the tube out

Characteristics

Characteristics	Symbol	Unit	Description
Connecting thread*			M5, G1/8, G1/4, G3/8, G1/2 (parallel and taper)
Tubing outside diameter*		mm	Ø4, Ø5, Ø6, Ø8, Ø10, Ø12, Ø14
Material			
- Housing			Nickel-plated brass
- O-rings			Silicone-free NBR
- Clamp			Stainless steel AISI316
- Thrust ring			Synthetics, black
Operating pressure range	p_{max}	bar	16 to 20°C
Temperature range	$T_{min/max}$	°C	-20 to +70 (other temperature ranges on request)
Medium			Compressed air (other media on request)

* depending on version

Tubing recommendations¹⁾

Tubing type	Calibrated tubing, surface hardness min. 65 Shore
Tubing outside diameter*	Ø4, Ø5, Ø6, Ø8, Ø10, Ø12, Ø14
Tubing diameter tolerance (outside diameter)	Ø4 to Ø8 mm: +0.1 / -0.1 Ø10 to Ø14 mm: +0.15 / -0.1
Tubing material	PA 12 or similar

¹⁾ see our range of tubing (Type PS-..) in section on tubing and hoses, pages 114, 115

Function

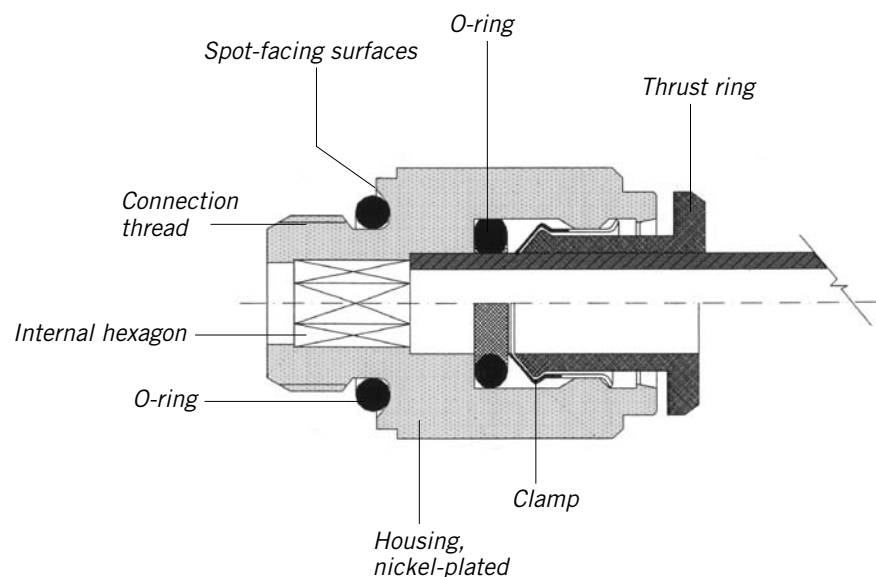

Straight adaptor, male parallel thread with O-ring

Order Instructions		ØD	G	ØC	ØB	H	L	SW1	SW2
Type	Bestell-Nr								
GS-54Msv	KW 0006	4	M5	2.5	9.0	4.0	20.5	Ø9.0	2.5
GS-184Msv	KW 0007	4	G1/8	2.6	13.5	6.0	20.0	9.0	2.5
GS-144Msv	KW 0861	4	G1/4	2.6	17.0	8.0	21.0	9.0	2.5
GS-55Msv	KW 0008	5	M5	2.6	9.5	4.0	22.0	Ø9.5	2.5
GS-185Msv	KW 0009	5	G1/8	4.2	13.5	6.0	22.0	10.0	4.0
GS-145Msv	KW 0010	5	G1/4	4.2	17.0	8.0	22.0	10.0	4.0
GS-56Msv	KW 0011	6	M5	2.6	10.5	4.0	22.5	Ø10.5	2.5
GS-186Msv	KW 0012	6	G1/8	4.2	13.5	6.0	24.0	11.0	4.0
GS-146Msv	KW 0013	6	G1/4	4.2	17.0	8.0	24.0	11.0	4.0
GS-188Msv	KW 0014	8	G1/8	5.2	12.8	6.0	26.5	13.0	5.0
GS-148Msv	KW 0015	8	G1/4	6.2	17.0	8.0	25.0	13.0	6.0
GS-388Msv	KW 0016	8	G3/8	6.2	20.0	9.0	25.0	13.0	6.0
GS-1410Msv	KW 0017	10	G1/4	7.3	16.0	8.0	29.0	16.0	7.0
GS-3810Msv	KW 0018	10	G3/8	8.3	21.0	9.0	29.5	16.0	8.0
GS-1210Msv	KW0982	10	G1/2	8.3	24.0	11.0	31.0	16.0	8.0
GS1214Msv	KW0019	12	G1/4	7.3	16.0	8.0	31.0	18.0	7.0
GS3812Msv	KW0020	12	G3/8	10.3	21.0	9.0	31.0	18.0	10.0
GS1212Msv	KW0021	12	G1/2	10.3	24.0	11.0	31.0	18.0	10.0
GS1214Msv	KW0022	14	G1/2	12.3	25.0	11.0	34.0	21.0	12.0

Straight adaptor, male taper thread

Order Instructions		ØD	R tap.	ØC	H	L	SW1	SW2
Type	Order No.							
GSK-184Msv	KW 0001	4	R1/8	2.6	7.0	22.5	10	2.5
GSK-186Msv	KW 0002	6	R1/8	4.2	7.0	24.5	11	4.0
GSK-146Msv	KW 0003	6	R1/4	4.2	11.0	24.5	14	4.0
GSK-188Msv	KW 0004	8	R1/8	5.2	7.0	27.5	13	5.0
GSK-148Msv	KW 0005	8	R1/4	5.2	11.0	27.5	14	5.0
GSK-388Msv	KW 0862	8	R3/8	5.2	11.5	28.0	17	5.0
GSK-1410Msv	KW 0863	10	R1/4	7.3	11.0	32.5	16	7.0
GSK-3810Msv	KW 0864	10	R3/8	8.3	11.5	32.5	17	8.0

Pressure gauge adaptor

Order Instructions		ØD	G	ØC	ØB	H	L	SW
Type	Order No.							
MS-184Msv	KW 0030	4	G1/8	3.0	11.0	6.0	26.5	9
MS-185Msv	KW 0031	5	G1/8	4.0	12.0	6.0	27.0	10
MS-186Msv	KW 0032	6	G1/8	5.0	11.0	6.0	27.0	11
MS-146Msv	KW 0033	6	G1/4	5.0	16.0	13.0	31.0	11
MS-188Msv	KW 0034	8	G1/8	7.0	11.0	6.0	28.0	13
MS-148Msv	KW 0035	8	G1/4	7.0	17.0	10.0	32.0	13
MS-1410Msv	KW 0036	10	G1/4	9.0	16.0	13.0	32.0	16

Dimensions in mm

Fittings and accessories

Metal push-in fittings

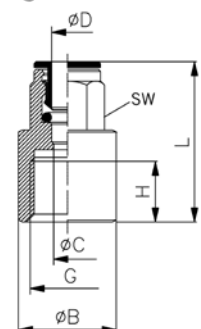
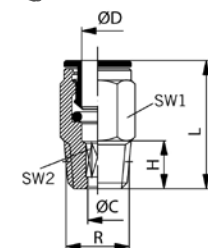
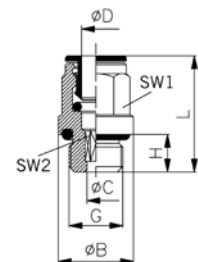

Fittings and accessories

Metal push-in fittings

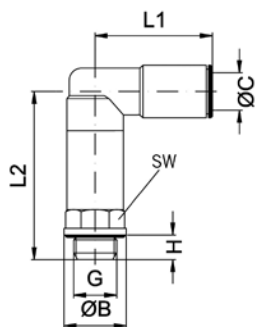
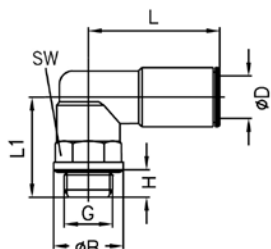
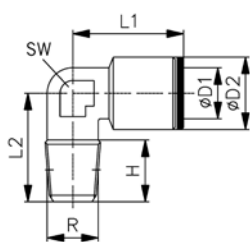

Elbow adaptor, male taper thread

Order Instructions		ØD1	R tap.	ØD2	H	L1	L2	SW
Type	Order No.							
LSK-184Msv	KW 0037	4	R1/8	9.0	8.0	18.6	16.5	10
LSK-186Msv	KW 0038	6	R1/8	11.0	8.0	22.5	16.5	10
LSK-146Msv	KW 0039	6	R1/4	11.0	12.0	23.0	22.0	12
LSK-188Msv	KW 0040	8	R1/8	13.0	9.0	25.0	18.5	11
LSK-148Msv	KW 0041	8	R1/4	13.0	12.0	25.0	22.0	11
LSK-1410Msv	KW 0043	10	R1/4	15.0	12.0	25.0	22.0	14

Elbow adaptor, swivelling, male parallel thread with O-ring

Order Instructions		ØD	G	ØB	H	L	L1	SW
Type	Order No.							
LDS-54Msv	KW 0049	4	M5	8.0	4.0	18.0	14.5	9
LDS-184Msv	KW 0050	4	G1/8	13.0	6.0	20.0	20.0	13
LDS-55Msv	KW 0051	5	M5	8.0	4.0	21.0	14.5	9
LDS-185Msv	KW 0052	5	G1/8	13.0	6.0	21.0	20.0	13
LDS-145Msv	KW 0053	5	G1/4	16.0	8.0	21.0	24.0	13
LDS-56Msv	KW 0872	6	M5	8.0	4.0	21.0	14.5	9
LDS-186Msv	KW 0054	6	G1/8	13.0	6.0	21.0	20.0	13
LDS-146Msv	KW 0055	6	G1/4	16.0	8.0	21.0	24.0	13
LDS-188Msv	KW 0056	8	G1/8	13.0	6.0	24.0	20.0	13
LDS-148Msv	KW 0057	8	G1/4	16.0	8.0	24.0	24.0	13
LDS-388Msv	KW 0058	8	G3/8	20.0	9.0	24.0	25.5	13
LDS-1410Msv	KW 0059	10	G1/4	16.0	8.0	27.0	24.0	16
LDS-3810Msv	KW 0060	10	G3/8	20.0	9.0	27.0	28.0	16
LDS-1210Msv	KW 0983	10	G1/2	25.0	11.0	27.0	30.0	16
LDS-1412Msv	KW 0061	12	G1/4	16.0	8.0	28.0	28.5	16
LDS-3812Msv	KW 0062	12	G3/8	20.0	9.0	28.0	28.5	20
LDS-1212Msv	KW 0873	12	G1/2	25.0	11.0	28.0	33.5	20
LDS-1214Msv	KW 0835	14	G1/2	25.0	11.0	31.0	33.5	20

For frequent swivelling, see Type ESS page 63

Extended elbow adaptor, swivelling, male parallel thread with O-ring

Order Instructions		ØD1	G	ØB	H	L1	L2	SW
Type	Order No.							
LDSSL-186Msv	KW 0756	6	G1/8	13	6	21.0	33.0	13
LDSSL-146Msv	KW 0757	6	G1/4	16	8	21.0	37.7	13
LDSSL-188Msv	KW 0754	8	G1/8	13	6	24.0	33.0	13
LDSSL-148Msv	KW 0755	8	G1/4	16	8	24.0	37.7	13

Dimensions in mm

Elbow adaptor, swivelling, male taper thread

Order Instructions		ØD	R tap.	L1	L2	H	SW
Type	Order No.						
LDSK-184Msv	KW 0044	4	R1/8	20.2	20.0	7.0	13
LDSK-186Msv	KW 0045	6	R1/8	20.2	21.0	7.0	13
LDSK-146Msv	KW 0046	6	R1/4	25.2	21.0	11.0	14
LDSK-188Msv	KW 0047	8	R1/8	20.2	24.0	7.0	13
LDSK-148Msv	KW 0048	8	R1/4	25.0	24.0	11.0	14
LDSK-388Msv	KW 0867	8	R3/8	28.0	24.0	11.0	18
LDSK-1410Msv	KW 0868	10	R1/4	26.0	27.0	11.0	16
LDSK-3810Msv	KW 0869	10	R3/8	30.0	27.0	11.0	16
LDSK-3812Msv	KW 0870	12	R3/8	32.5	28.0	11.0	20

For frequent swivelling, see Type ESS below

Banjo elbow adaptor, male parallel thread with O-ring

Order Instructions		ØD	G	ØA	H	L1	L	SW
Type	Order No.							
ESS-54Msv	KW 0148	4	M5	2.0	4	17.0	18.5	2
ESS-184Msv	KW 0149	4	G1/8	5.5	6	25.0	21.0	3
ESS-55Msv	KW 0150	5	M5	2.0	4	17.0	19.5	2
ESS-185Msv	KW 0151	5	G1/8	5.5	6	25.0	22.5	3
ESS-186Msv	KW 0152	6	G1/8	5.5	6	25.0	23.5	3
ESS-188Msv	KW 0154	8	G1/8	5.5	6	25.0	24.5	3
ESS-146Msv	KW 0153	6	G1/4	7.8	8	29.3	24.5	4
ESS-148Msv	KW 0155	8	G1/4	7.8	8	29.3	26.0	4
ESS-1410Msv	KW 0156	10	G1/4	7.8	8	29.3	27.0	4

Application: for frequent swivelling

Double banjo elbow adaptor, male parallel thread with O-ring

Order Instructions		ØD	G	ØB	H	L1	L2	L3	L4	SW
Type	Order No.									
ZSS-184Msv	KW 0887	4	G1/8	13	6	44	19.0	15	21	14
ZSS-186Msv	KW 0888	6	G1/8	13	6	44	19.0	15	23	14
ZSS-188Msv	KW 0890	8	G1/8	13	6	44	19.0	15	24	14
ZSS-146Msv	KW 0889	6	G1/4	17	8	50	22.5	17	24	17
ZSS-148Msv	KW 0891	8	G1/4	17	8	50	22.5	17	26	17
ZSS-1410Msv	KW 0892	10	G1/4	17	8	50	22.5	17	27	17

Application: for frequent swivelling

Dimensions in mm

Fittings and accessories

Metal push-in fittings

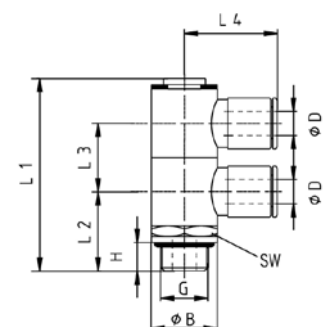
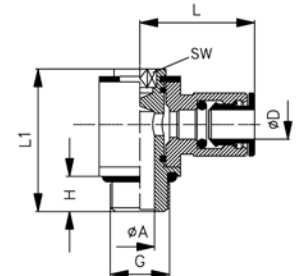
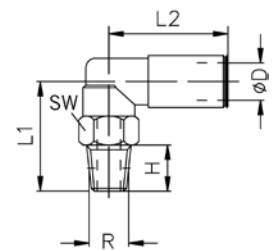

Fittings and accessories

Metal push-in fittings

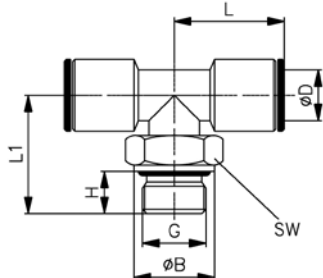
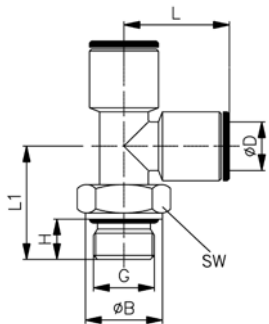
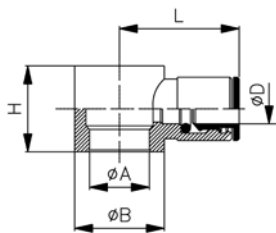

Banjo elbow body, for banjo bolt*

Order Instructions Type	Order No.	ØD	to banjo bolt	ØA	ØB	H	L
RES-54Msv	KW 0126	4	M5	5.0	SW9	9.0	19.0
RES-184Msv	KW 0127	4	G1/8	9.9	14	15.0	21.0
RES-55Msv	KW 0128	5	G1/8	5.0	SW9	9.0	19.0
RES-185Msv	KW 0129	5	G1/8	9.9	14	15.0	22.5
RES-186Msv	KW 0130	6	G1/8	9.9	14	15.0	23.0
RES-146Msv	KW 0131	6	G1/4	13.3	18	17.0	24.0
RES-188Msv	KW 0132	8	G1/4	9.9	14	15.0	24.5
RES-148Msv	KW 0133	8	G1/4	13.3	18	17.0	26.0
RES-388Msv	KW 0881	8	G3/8	16.6	21	20.0	28.0
RES-1410Msv	KW 0134	10	G1/4	13.3	18	17.0	27.0
RES-3810Msv	KW 0135	10	G3/8	16.6	21	20.0	29.0
RES-1412Msv	KW 0882	12	G1/4	13.3	18	17.0	28.0
RES-3812Msv	KW 0136	12	G3/8	16.6	21	20.0	30.0

Run tee adaptor, swivelling, male parallel thread with O-ring

Order Instructions Type	Order No.	ØD	G	ØB	H	L	L1	SW
WDS-184Msv	KW 0080	4	G1/8	13.0	6.0	17.5	18.5	13
WDS-186Msv	KW 0082	6	G1/8	13.0	6.0	22.0	20.0	13
WDS-146Msv	KW 0083	6	G1/4	16.0	8.0	22.0	24.0	13
WDS-188Msv	KW 0084	8	G1/8	13.0	6.0	24.0	20.0	13
WDS-148Msv	KW 0085	8	G1/4	16.0	8.0	24.0	24.0	13
WDS-1410Msv	KW 0086	10	G1/4	16.0	8.0	27.0	24.0	16
WDS-3810Msv	KW 0087	10	G3/8	20.0	9.0	27.0	28.0	16
WDS-3812Msv	KW 0088	12	G3/8	20.0	9.0	21.0	26.5	18

Branch tee adaptor, swivelling, male parallel thread with O-ring

Order Instructions Type	Order No.	ØD	G	ØB	H	L	L1	SW
TDS-186Msv	KW 0072	6	G1/8	13.0	6.0	21.0	20.0	13
TDS-146Msv	KW 0073	6	G1/4	16.0	8.0	21.0	24.0	13
TDS-188Msv	KW 0074	8	G1/8	13.0	6.0	24.0	20.0	13
TDS-148Msv	KW 0075	8	G1/4	16.0	8.0	24.0	24.0	13
TDS-388Msv	KW 0076	8	G3/8	20.0	9.0	24.0	25.5	16
TDS-1410Msv	KW 0077	10	G1/4	16.0	8.0	26.0	24.0	16
TDS-3810Msv	KW 0078	10	G3/8	20.0	9.0	26.0	28.0	16
TDS-3812Msv	KW 0079	12	G3/8	20.0	9.0	29.0	28.5	20
TDS-1214Msv	KW 0876	14	G1/2	25.0	11.0	32.0	33.5	20

For frequent swivelling, see Type TSS on page 65

* For banjo bolts see pages 96, 97

Dimensions in mm

Banjo tee adaptor, male parallel thread with O-ring

Order Instructions		ØD	G	ØA	H	L1	L	SW
Type	Order No.							
TSS-54Msv	KW 0157	4	M5	2.0	4	17.0	18.5	2
TSS-184Msv	KW 0158	4	G1/8	5.5	6	25.0	21.0	3
TSS-55Msv	KW 0159	5	M5	2.0	4	17.0	19.5	2
TSS-185Msv	KW 0160	5	G1/8	5.5	6	25.0	22.5	3
TSS-186Msv	KW 0161	6	G1/8	5.5	6	25.0	23.0	3
TSS-188Msv	KW 0163	8	G1/8	5.5	6	25.0	24.0	3
TSS-146Msv	KW 0162	6	G1/4	7.8	8	29.3	24.0	4
TSS-148Msv	KW 0164	8	G1/4	7.8	8	29.3	26.0	4
TSS-1410Msv	KW 0165	10	G1/4	7.8	8	29.3	27.0	4

Application: for frequent swivelling

Banjo tee body, for banjo bolt*

Order Instructions		ØD	to banjo bolt	ØA	ØB	H	L
Type	Order No.						
RDS-54Msv	KW 0137	4	M5	5.0	8	9.0	18.5
RDS-184Msv	KW 0138	4	G1/8	9.9	14	15.0	21.0
RDS-55Msv	KW 0139	5	M5	5.0	7	9.5	19.5
RDS-185Msv	KW 0140	5	G1/8	9.9	14	15.0	22.5
RDS-186Msv	KW 0141	6	G1/8	9.9	14	15.0	23.0
RDS-146Msv	KW 0142	6	G1/4	13.3	18	17.0	24.0
RDS-188Msv	KW 0143	8	G1/8	9.9	14	15.0	24.5
RDS-148Msv	KW 0144	8	G1/4	13.3	18	17.0	26.0
RDS-388Msv	KW 0884	8	G3/8	16.6	21	20.0	28.0
RDS-1410Msv	KW 0145	10	G1/4	13.3	18	17.0	27.0
RDS-3810Msv	KW 0146	10	G3/8	16.6	21	20.0	29.0
RDS-3812Msv	KW 0147	12	G3/8	16.6	21	20.0	30.0

* For banjo bolts see pages 96, 97

Fittings and accessories

Metal push-in fittings

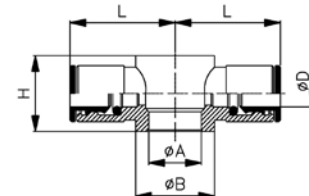
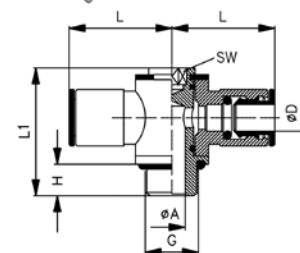

Dimensions in mm

Fittings and accessories

Metal push-in fittings

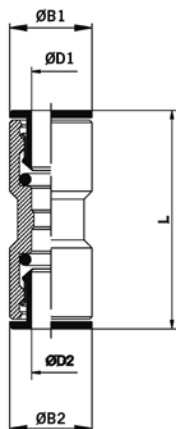

Straight connector

Order Instructions		ØD1	ØD2	NW	ØB1	L
Type	Order No.					
GVS-4Msv	KW 0023	4	4	3.0	9.0	30.0
GVS-5Msv	KW 0024	5	5	4.0	9.5	32.0
GVS-6Msv	KW 0025	6	6	5.0	11.0	31.5
GVS-8Msv	KW 0026	8	8	7.0	13.0	36.0
GVS-10Msv	KW 0027	10	10	9.0	15.0	37.0
GVS-12Msv	KW 0028	12	12	11.0	17.0	40.5
GVS-14Msv	KW 0029	14	14	12.0	20.0	45.0

Reducing straight connector

Order Instructions		ØD1	ØD2	NW	ØB1	ØB2	L
Type	Order No.						
GVSR-64Msv	KL5593	6	4	3.0	11	9	33.5
GVSR-86Msv	KL5594	8	6	5.0	13	11	37.0
GVSR-108Msv	KL5595	10	8	7.0	16	13	39.5
GVSR-1210Msv	KL5596	12	10	9.0	17	15	40.0
GVSR-1412Msv	KL5597	14	12	11.0	20	17	43.0

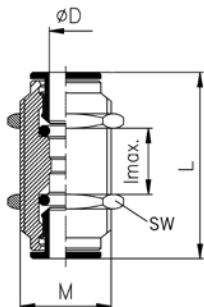

Straight bulkhead connector

Order Instructions		ØD	NW	M	I _{max}	L	SW
Type	Order No.						
SOS-4Msv	KW 0101	4	3.0	M10x1	8	32.0	13
SOS-5Msv	KW 0102	5	4.0	M11x1	8	33.0	14
SOS-6Msv	KW 0103	6	5.0	M14x1	8	33.5	17
SOS-8Msv	KW 0104	8	7.0	M16x1	10	37.0	18
SOS-10Msv	KW 0105	10	9.0	M17x1	12	39.5	20
SOS-12Msv	KW 0106	12	11.0	M20x1	17	42.0	24
SOS-14Msv	KW 0107	14	12.0	M22x1	18	45.0	25

Dimensions in mm

Equal elbow connector

Order Instructions		ØD	ØC	ØB	L
Type	Order No.				
WS-4Msv	KW 0063	4	3.0	9.0	17.5
WS-5Msv	KW 0064	5	4.0	9.5	19.0
WS-6Msv	KW 0065	6	5.0	11.0	19.5
WS-8Msv	KW 0066	8	7.0	13.0	23.0
WS-10Msv	KW 0067	10	8.0	15.0	25.0
WS-12Msv	KW 0068	12	10.0	17.0	27.0
WS-14Msv	KW 0069	14	12.0	20.0	30.0

Equal tee connector

Order Instructions		ØD1	ØD2	ØC	ØB	L
Type	Order No.					
TVS-4Msv	KW 0089	4	4	3.0	9.0	17.5
TVS-5Msv	KW 0090	5	5	4.0	9.5	19.0
TVS-6Msv	KW 0091	6	6	5.0	11.0	19.5
TVS-8Msv	KW 0092	8	8	7.0	13.0	23.0
TVS-10Msv	KW 0093	10	10	8.0	15.0	25.0
TVS-12Msv	KW 0094	12	14	10.0	17.0	27.0
TVS-14Msv	KW 0095	14	14	12.0	20.0	30.0

Reducing straight stem connector

Order Instructions		ØD1	ØD2	ØC	ØB	L
Type	Order No.					
R-54Msv	KW 0108	5	4	3.0	9.0	32.5
R-64Msv	KW 0109	6	4	3.0	9.0	28.5
R-65Msv	KW 0111	6	5	4.0	9.5	35.5
R-84Msv	KW 0110	8	4	3.0	9.0	31.0
R-85Msv	KW 0112	8	5	4.0	9.5	32.5
R-86Msv	KW 0113	8	6	5.0	10.5	33.5
R-106Msv	KW 0114	10	6	5.0	10.5	36.5
R-108Msv	KW 0116	10	8	7.0	13.0	38.0
R-126Msv	KW 0115	12	6	5.0	13.0	39.5
R-128Msv	KW 0117	12	8	7.0	13.0	38.5
R-1210Msv	KW 0118	12	10	9.0	15.0	41.0
R-148Msv	KW 0834	14	8	7.0	15.0	43.0

Dimensions in mm

Fittings and accessories

Metal push-in fittings

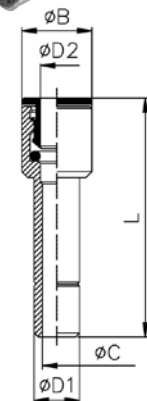
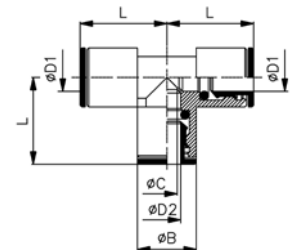
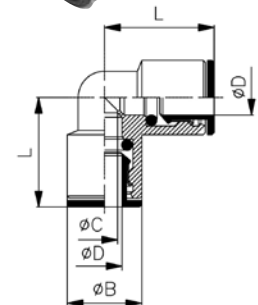

Fittings and accessories

Metal push-in fittings

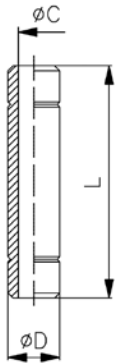
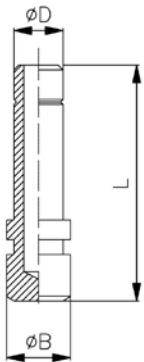

Blanking Plug

Order Instructions Type	Order No.	$\varnothing D$	$\varnothing B$	L
VST-4Msv	KW 0119	4	5.0	25.5
VST-5Msv	KW 0120	5	6.0	26.5
VST-6Msv	KW 0121	6	7.0	27.5
VST-8Msv	KW 0122	8	9.0	30.5
VST-10Msv	KW 0123	10	11.0	35.0
VST-12Msv	KW 0124	12	13.0	37.0
VST-14Msv	KW 0125	14	15.0	40.0

Straight stem connector

Order Instructions Type	Order No.	$\varnothing D$	$\varnothing C$	L
VR-4	KW 0854	4	2.0	32.0
VR-5	KW 0855	5	3.0	33.0
VR-6	KW 0856	6	4.0	35.0
VR-8	KW 0857	8	6.0	38.0
VR-10	KW 0858	10	8.0	45.5
VR-12	KW 0859	12	10.0	48.0
VR-14	KW 0860	14	12.0	52.0

Contents

Description	Page
Characteristics	70
Straight adaptors	71, 72
Elbow adaptors	73, 74
Run tee, branch tee and Y adaptors	75–77
Connectors	78–81, 83, 85
Banjo elbow adaptor	82, 84

Fittings and accessories

Plastic push-in fittings



Fittings and accessories

Plastic push-in fittings

Connection System for fast assembly/dismantling without tools

- Cost reductions through fast assembly and dismantling
- No passage area reduction relative to the diameter of the plastic tubing
- High reliability through profile seal
- O-ring seal on thread
- Stainless steel collet
- Suitable for plastic tubing and copper, steel and stainless steel piping
- Nickel-plated brass for optimum surface protection

Characteristics

Characteristics	Symbol	Unit	Description
Connecting thread*			M3, M5, M6, G1/8, G1/4, G3/8, G1/2 (parallel and taper)
Tubing outside diameter*		mm	Ø3, Ø4, Ø6, Ø8, Ø10, Ø12, Ø16
Material			
- Body and sleeve			Brass/POM
- Release ring			POM
- Clamp			Stainless steel
- O-ring			Buna N (NBR)
Operating pressure range	p_{max}	bar	10 (and vacuum)
Temperature range	$T_{min/max}$	°C	0 to +60 (other temperature ranges on request)
Medium			Compressed air (vacuum)

* depending on version

Tubing recommendations¹⁾

Tubing type	Calibrated tubing, surface hardness min. 65 Shore
Tubing outside diameter*	Ø3, Ø4, Ø6, Ø8, Ø10, Ø12, Ø16
Tubing material	PU, PA, PE or similar

¹⁾ see our range of tubing (Type PS-..) in section on tubing and hoses, pages 114, 115

Straight adaptor

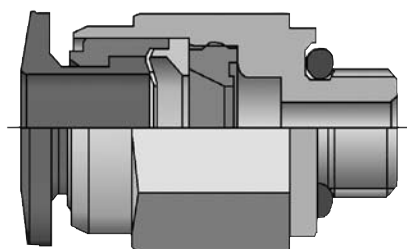

Elbow adaptor

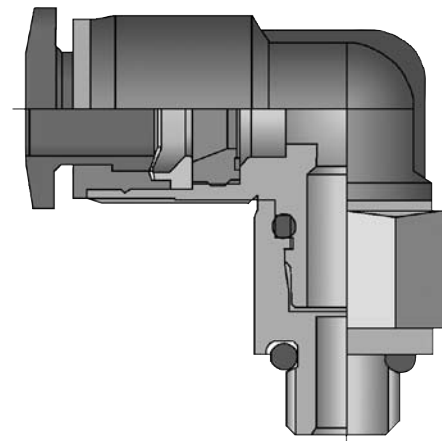

Dimensions in mm

Straight adaptor, male parallel thread with O-ring

Order Instructions Type	Order No.	Tube Ø OD	Port size	L	A	F	B	SW	SW1
GS-54Msv	KT0100	4	M5	21.9	4.6	15.9	5	2	10
GS-184Msv	KT0101	4	G1/8	21.5	6.0	15.9	7	3	13
GS-144Msv	KT0102	4	G1/4	23.5	8.0	15.9	8	3	15
GS-56Msv	KT0103	6	M5	23.6	4.6	16.5	9	2	12
GS-186Msv	KT0104	6	G1/8	22.5	6.0	16.5	7	4	13
GS-146Msv	KT0105	6	G1/4	24.5	8.0	16.5	8	5	15
GS-386Msv	KT0106	6	G3/8	25.5	8.0	16.5	7	5	17
GS-188Msv	KT0107	8	G1/8	26.7	6.0	17.7	9	5	15
GS-148Msv	KT0108	8	G1/4	26.7	8.0	17.7	8	6	15
GS-388Msv	KT0109	8	G3/8	25.0	8.0	17.7	8	6	17
GS-128Msv	KT0110	8	G1/2	26.0	9.0	17.7	8	6	21
GS-1410Msv	KT0111	10	G1/4	30.0	8.0	18.6	9	8	17
GS-3810Msv	KT0112	10	G3/8	27.0	8.0	18.6	8	8	17
GS-1210Msv	KT0113	10	G1/2	28.3	9.0	18.6	8	8	21
GS-1412Msv	KT0114	12	G1/4	32.2	8.0	20.9	9	8	19
GS-3812Msv	KT0115	12	G3/8	31.6	8.0	20.9	8	8	19
GS-1212Msv	KT0116	12	G1/2	31.6	9.0	20.9	8	8	21
GS-3816Msv	KT0117	16	G3/8	36.2	8.0	24.7	16	10	24
GS-1216Msv	KT0118	16	G1/2	36.2	9.0	24.7	15	10	24

Material: nickel-plated brass

Straight adaptor, PTFE-coated male taper thread, external hexagon

Order Instructions Type	Order No.	Tube Ø OD	Port size	L	A	F	SW
GSK-184Msv	KT0119	4	R1/8	21.8	8	15.9	10
GSK-186Msv	KT0120	6	R1/8	21.6	8	16.5	12
GSK-146Msv	KT0121	6	R1/4	21.6	10	16.5	14
GSK-188Msv	KT0122	8	R1/8	28.2	8	17.7	12
GSK-148Msv	KT0123	8	R1/4	26.0	10	17.7	14
GSK-388Msv	KT0124	8	R3/8	23.7	11	17.7	17
GSK-1410Msv	KT0125	10	R1/4	31.2	10	18.6	14
GSK-3810Msv	KT0126	10	R3/8	25.3	11	18.6	17
GSK-1210Msv	KT0127	10	R1/2	30.3	14	18.6	22
GSK-1412Msv	KT0128	12	R1/4	33.7	10	20.9	14
GSK-3812Msv	KT0129	12	R3/8	30.6	11	20.9	17
GSK-1212Msv	KT0130	12	R1/2	30.4	14	20.9	22

Material: nickel-plated brass

Fittings and accessories

Plastic push-in fittings

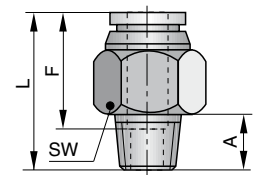
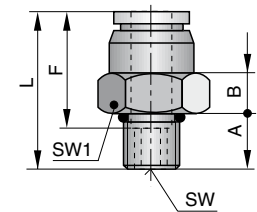

Dimensions in mm

Fittings and accessories

Plastic push-in fittings

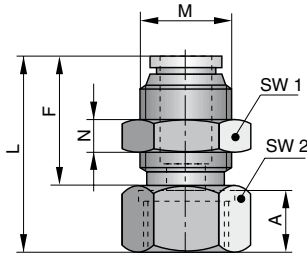
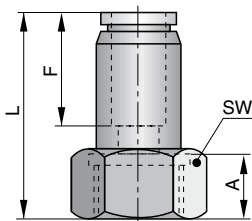
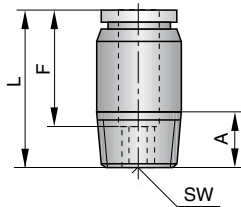

Straight adaptor, PTFE-coated male taper thread, hexagon socket

Order Instructions		Tube Ø OD	Port size	L	A	F	SW
Type	Order No.						
GSKR-54Msv	KT0131	4	M5	21.8	4.6	15.9	2
GSKR-184Msv	KT0132	4	R1/8	20.4	8.0	15.9	3
GSKR-56Msv	KT0133	6	M5	22.6	4.6	16.5	2
GSKR-186Msv	KT0134	6	R1/8	21.8	8.0	16.5	4
GSKR-146Msv	KT0135	6	R1/4	22.5	10.0	16.5	4
GSKR-188Msv	KT0136	8	R1/8	27.0	8.0	17.7	4
GSKR-148Msv	KT0137	8	R1/4	25.0	10.0	17.7	6
GSKR-388Msv	KT0138	8	R3/8	25.0	110.0	17.7	6
GSKR-1410Msv	KT0139	10	R1/4	26.6	10.0	18.6	6
GSKR-3810Msv	KT0140	10	R3/8	26.6	11.0	18.6	6
GSKR-1210Msv	KT0141	10	R1/2	26.6	14.0	18.6	6
GSKR-3812Msv	KT0142	12	R3/8	32.4	11.0	20.9	8
GSKR-1212Msv	KT0143	12	R1/2	32.4	14.0	20.9	8

Material: nickel-plated brass

Straight adaptor, female parallel thread

Order Instructions		Tube Ø OD	Port size	L	A	F	SW
Type	Order No.						
GMS-184Msv	KT0144	4	G1/8	26.8	10	15.9	14
GMS-186Msv	KT0145	6	G1/8	28.3	10	16.5	14
GMS-146Msv	KT0146	6	G1/4	30.0	11	16.5	17
GMS-188Msv	KT0147	8	G1/8	29.1	10	17.7	14
GMS-148Msv	KT0148	8	G1/4	31.2	11	17.7	17
GMS-388Msv	KT0149	8	G3/8	32.5	12	17.7	22
GMS-1410Msv	KT0150	10	G1/4	32.7	11	18.6	17
GMS-3810Msv	KT0151	10	G3/8	33.3	12	18.6	22
GMS-3812Msv	KT0152	12	G3/8	37.1	12	20.9	22
GMS-1212Msv	KT0153	12	G1/2	39.2	14	20.9	24

Material: nickel-plated brass

Straight bulkhead adaptor, female parallel thread

Order Instructions		Tube Ø OD	Port size	L	N	M	A	F	SW1	SW2
Type	Order No.									
SOS-184Msv	KT0154	4	G1/8	27.0	4	M12 x 1	9	16.8	14	14
SOS-186Msv	KT0155	6	G1/8	29.1	4	M14 x 1	9	17.6	17	17
SOS-146Msv	KT0156	6	G1/4	31.2	4	M14 x 1	11	17.6	17	17
SOS-188Msv	KT0157	8	G1/8	32.3	5	M16 x 1	9	18.7	19	19
SOS-148Msv	KT0158	8	G1/4	31.1	5	M16 x 1	11	18.7	19	19
SOS-388Msv	KT0159	8	G3/8	32.9	5	M16 x 1	12	18.7	19	22
SOS-1410Msv	KT0160	10	G1/4	34.0	5	M20 x 1	11	19.6	24	24
SOS-3810Msv	KT0161	10	G3/8	33.9	5	M20 x 1	12	19.6	24	24
SOS-3812Msv	KT0162	12	G3/8	38.7	5	M22 x 1	12	21.9	26	24
SOS-1212Msv	KT0163	12	G1/2	40.6	5	M22 x 1	14	21.9	26	24

Material: nickel-plated brass

Dimensions in mm

Elbow adaptor, swivelling, male parallel thread with O-ring

Order Instructions		Tube Ø OD	Port size	L	H	A	F	SW
Type	Order No.							
LDS-54KU	KT0164	4	M5	27.3	23.8	4.6	16.8	10
LDS-184KU	KT0165	4	G1/8	27.4	23.8	6.0	16.8	14
LDS-144KU	KT0166	4	G1/4	29.4	23.8	8.0	16.8	17
LDS-56KU	KT0167	6	M5	30.3	26.5	4.5	17.6	12
LDS-186KU	KT0168	6	G1/8	30.6	26.5	6.0	17.6	14
LDS-146KU	KT0169	6	G1/4	32.6	26.5	8.0	17.6	17
LDS-386KU	KT0170	6	G3/8	33.6	26.5	9.0	17.6	20
LDS-188KU	KT0171	8	G1/8	32.9	29.7	6.0	18.7	14
LDS-148KU	KT0172	8	G1/4	34.9	29.7	8.0	18.7	17
LDS-388KU	KT0173	8	G3/8	35.9	29.7	9.0	18.7	20
LDS-1410KU	KT0174	10	G1/4	37.4	32.1	8.0	19.6	17
LDS-3810KU	KT0175	10	G3/8	38.4	32.1	9.0	19.6	20
LDS-1210KU	KT0176	10	G1/2	39.4	32.1	10.0	19.6	24
LDS-1412KU	KT0177	12	G1/4	41.4	36.9	8.0	21.9	19
LDS-3812KU	KT0178	12	G3/8	42.4	36.9	9.0	21.9	20
LDS-1212KU	KT0179	12	G1/2	43.4	36.9	10.0	21.9	24
LDS-3816KU	KT0180	16	G3/8	53.8	44.2	9.0	23.9	24
LDS-1216KU	KT0181	16	G1/2	54.8	44.2	10.0	23.9	24

Material: Plastic, nickel-plated brass

Fittings and accessories

Plastic push-in fittings

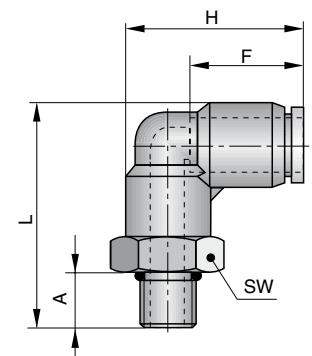

Elbow adaptor, swivelling, PTFE-coated male taper thread

Order Instructions		Tube Ø OD	Port size	L	H	A	F	SW
Type	Order No.							
LDSK-184KU	KT0182	4	R1/8	29.8	23.8	8	16.8	10
LDSK-186KU	KT0183	6	R1/8	32.8	26.5	8	17.6	12
LDSK-146KU	KT0184	6	R1/4	35.8	26.5	10	17.6	14
LDSK-188KU	KT0185	8	R1/8	35.2	29.7	8	18.7	14
LDSK-148KU	KT0186	8	R1/4	38.2	29.7	10	18.7	14
LDSK-388KU	KT0187	8	R3/8	39.2	29.7	11	18.7	17
LDSK-1410KU	KT0188	10	R1/4	40.3	32.1	10	19.6	17
LDSK-3810KU	KT0189	10	R3/8	41.3	32.1	11	19.6	17
LDSK-1210KU	KT0190	10	R1/2	44.3	32.1	14	19.6	22
LDSK-1412KU	KT0191	12	R1/4	44.7	36.9	10	21.9	19
LDSK-3812KU	KT0192	12	R3/8	45.7	36.9	11	21.9	19
LDSK-1212KU	KT0193	12	R1/2	48.7	36.9	14	21.9	22

Material: Plastic, nickel-plated brass

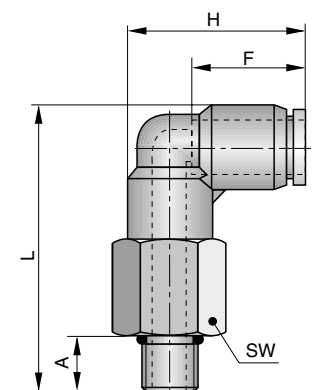

Dimensions in mm

Fittings and accessories

Plastic push-in fittings

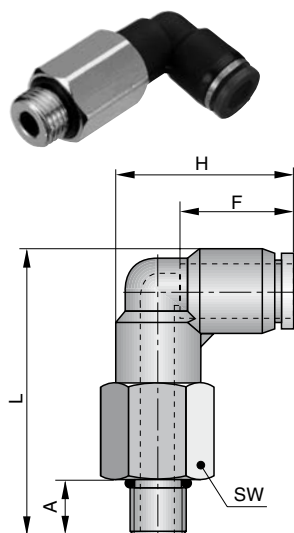

Extended elbow adaptor, swivelling, male parallel thread with O-ring (long version)

Order Instructions Type	Order No.	Tube Ø OD	Port size	L	H	A	F	SW
LDSL-54KU	KT0194	4	M5	38.8	23.8	4.6	16.8	10
LDSL-184KU	KT0195	4	G1/8	39.4	23.8	6.0	16.8	14
LDSL-144KU	KT0196	4	G1/4	41.4	23.8	8.0	16.8	17
LDSL-56KU	KT0197	6	M5	44.3	26.5	4.6	17.6	12
LDSL-186KU	KT0198	6	G1/8	45.6	26.5	6.0	17.6	14
LDSL-146KU	KT0199	6	G1/4	47.6	26.5	8.0	17.6	17
LDSL-386KU	KT0200	6	G3/8	48.6	26.5	9.0	17.6	20
LDSL-188KU	KT0201	8	G1/8	50.9	29.7	6.0	18.7	14
LDSL-148KU	KT0202	8	G1/4	52.9	29.7	8.0	18.7	17
LDSL-388KU	KT0203	8	G3/8	53.9	29.7	9.0	18.7	20
LDSL-1410KU	KT0204	10	G1/4	57.4	32.1	8.0	19.6	17
LDSL-3810KU	KT0205	10	G3/8	58.4	32.1	9.0	19.6	20
LDSL-1210KU	KT0206	10	G1/2	59.4	32.1	10.0	19.6	24
LDSL-1412KU	KT0207	12	G1/4	66.4	36.9	8.0	21.9	19
LDSL-3812KU	KT0208	12	G3/8	67.4	36.9	9.0	21.9	20
LDSL-1212KU	KT0209	12	G1/2	68.4	36.9	10.0	21.0	24

Material: Plastic, nickel-plated brass

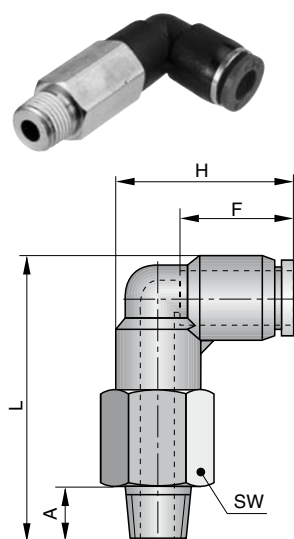

Extended elbow adaptor, swivelling, PTFE-coated male taper thread (long version)

Order Instructions Type	Order No.	Tube Ø OD	Port size	L	H	A	F	SW
LDSLK-184KU	KT0210	4	R1/8	40.8	23.8	8	16.8	10
LDSLK-186KU	KT0211	6	R1/8	46.3	26.5	8	17.6	12
LDSLK-146KU	KT0212	6	R1/4	48.3	26.5	10	17.6	14
LDSLK-188KU	KT0213	8	R1/8	51.2	29.7	8	18.7	14
LDSLK-148KU	KT0214	8	R1/4	53.2	29.7	10	18.7	14
LDSLK-388KU	KT0215	8	R3/8	54.2	29.7	11	18.7	17
LDSLK-1410KU	KT0216	10	R1/4	50.5	32.1	10	19.6	14
LDSLK-3810KU	KT0217	10	R3/8	51.5	32.1	11	19.6	17
LDSLK-1210KU	KT0218	10	R1/2	54.5	32.1	14	19.6	22
LDSLK-1412KU	KT0219	12	R1/4	66.2	36.9	10	21.9	19
LDSLK-3812KU	KT0220	12	R3/8	67.2	36.9	11	21.9	19
LDSLK-1212KU	KT0221	12	R1/2	70.2	36.9	14	21.9	22

Material: Plastic, nickel-plated brass

Dimensions in mm

Run tee adaptor, swivelling, male parallel thread with O-ring

Order Instructions		Tube Ø OD	Port size	L	H	A	F	SW
Type	Order No.							
WDS-54KU	KT0222	4	M5	42.3	25.1	4.6	16.8	10
WDS-184KU	KT0223	4	G1/8	42.8	25.1	6.0	16.8	14
WDS-56KU	KT0224	6	M5	46.1	28.1	4.6	17.6	10
WDS-186KU	KT0225	6	G1/8	46.9	28.1	6.0	17.6	14
WDS-146KU	KT0226	6	G1/4	48.9	28.1	8.0	17.6	17
WDS-188KU	KT0227	8	G1/8	50.1	30.9	6.0	18.7	14
WDS-148KU	KT0228	8	G1/4	52.1	30.9	8.0	18.7	17
WDS-388KU	KT0229	8	G3/8	53.1	30.9	9.0	18.7	20
WDS-1410KU	KT0230	10	G1/4	55.9	34.6	8.0	19.6	17
WDS-3810KU	KT0231	10	G3/8	56.8	34.6	9.0	19.6	20
WDS-1210KU	KT0232	10	G1/2	57.8	34.6	10.0	19.6	24
WDS-3812KU	KT0233	12	G3/8	63.2	40.3	9.0	21.9	20
WDS-1212KU	KT0234	12	G1/2	64.2	40.3	10.0	21.9	24

Material: Plastic, nickel-plated brass

Fittings and accessories

Plastic push-in fittings

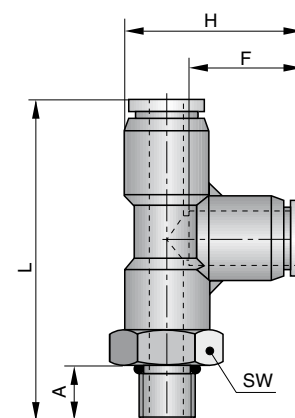

Run tee adaptor, swivelling, PTFE-coated male taper thread

Order Instructions		Tube Ø OD	Port size	L	H	A	F	SW
Type	Order No.							
WDSK-184KU	KT0235	4	R1/8	45.3	25.1	8	16.8	10
WDSK-186KU	KT0236	6	R1/8	48.6	28.1	8	17.6	12
WDSK-146KU	KT0237	6	R1/4	51.2	28.1	10	17.6	14
WDSK-188KU	KT0238	8	R1/8	52.2	30.9	8	18.7	12
WDSK-148KU	KT0239	8	R1/4	55.2	30.9	10	18.7	14
WDSK-388KU	KT0240	8	R3/8	56.2	30.9	11	18.7	17
WDSK-1410KU	KT0241	10	R1/4	58.6	34.6	10	19.6	14
WDSK-3810KU	KT0242	10	R3/8	59.6	34.6	11	19.6	17
WDSK-1210KU	KT0243	10	R1/2	62.6	34.6	14	19.6	22
WDSK-3812KU	KT0244	12	R3/8	65.8	40.3	11	21.9	17
WDSK-1212KU	KT0245	12	R1/2	68.8	40.3	14	21.9	22

Material: Plastic, nickel-plated brass

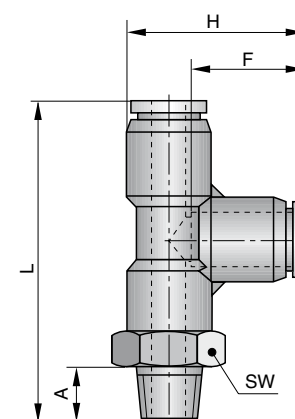

Dimensions in mm

Fittings and accessories

Plastic push-in fittings

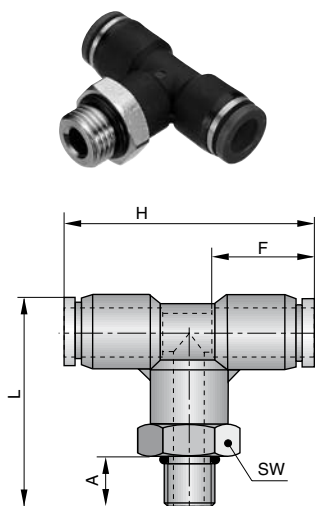

Branch tee adaptor, swivelling, male parallel thread with O-ring

Order Instructions Type	Order No.	Tube Ø OD	Port size	L	H	A	F	SW
TDS-54KU	KT0246	4	M5	27.3	37.6	4.6	16.8	10
TDS-184KU	KT0247	4	G1/8	27.8	37.6	6.0	16.8	14
TDS-56KU	KT0248	6	M5	30.3	41.0	4.6	17.6	12
TDS-186KU	KT0249	6	G1/8	30.8	41.0	6.0	17.6	14
TDS-146KU	KT0250	6	G1/4	32.8	41.0	8.0	17.6	17
TDS-188KU	KT0251	8	G1/8	33.3	44.4	6.0	18.7	14
TDS-148KU	KT0252	8	G1/4	35.3	44.4	8.0	18.7	17
TDS-388KU	KT0253	8	G3/8	36.3	44.4	9.0	18.7	20
TDS-1410KU	KT0254	10	G1/4	37.3	47.2	8.0	19.6	17
TDS-3810KU	KT0255	10	G3/8	38.3	47.2	9.0	19.6	20
TDS-1210KU	KT0256	10	G1/2	39.3	47.2	10.0	19.6	24
TDS-1412KU	KT0257	12	G1/4	41.7	54.8	8.0	21.9	19
TDS-3812KU	KT0258	12	G3/8	42.7	54.8	9.0	21.9	20
TDS-1212KU	KT0259	12	G1/2	43.7	54.8	10.0	21.9	24
TDS-3816KU	KT0478	16	G3/8	52.6	64.5	9.0	24.0	24
TDS-1216KU	KT0479	16	G1/2	53.6	64.6	10.0	24.0	24

Material: Plastic, nickel-plated brass

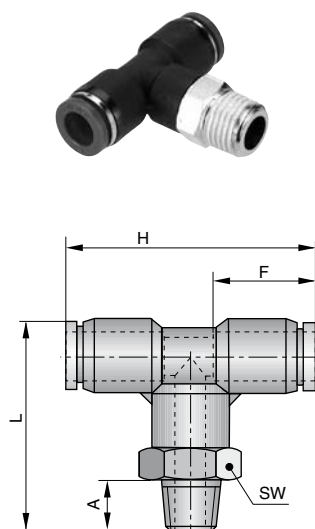

Branch tee adaptor, swivelling, PTFE-coated male taper thread

Order Instructions Type	Order No.	Tube Ø OD	Port size	L	H	A	F	SW
TDSK-184KU	KT0260	4	R1/8	29.8	37.6	8	16.8	10
TDSK-186KU	KT0261	6	R1/8	32.8	41.0	8	17.6	12
TDSK-146KU	KT0262	6	R1/4	35.8	41.0	10	17.6	14
TDSK-188KU	KT0263	8	R1/8	35.3	44.4	8	18.7	12
TDSK-148KU	KT0264	8	R1/4	38.3	44.4	10	18.7	14
TDSK-388KU	KT0265	8	R3/8	39.3	44.4	11	18.7	17
TDSK-1410KU	KT0266	10	R1/4	41.6	50.6	10	19.6	14
TDSK-3810KU	KT0267	10	R3/8	42.9	50.6	11	19.6	17
TDSK-1210KU	KT0268	10	R1/2	45.5	50.6	14	19.6	22
TDSK-1412KU	KT0269	12	R1/4	44.7	54.8	10	21.9	14
TDSK-3812KU	KT0270	12	R3/8	45.7	54.8	11	21.9	17
TDSK-1212KU	KT0271	12	R1/2	48.7	54.8	14	21.9	22

Material: Plastic, nickel-plated brass

Dimensions in mm

Parallel Y adaptor, swivelling, male parallel thread with O-ring

Order Instructions Type	Order No.	Tube Ø OD	Port size	L	H	A	F	SW
YDS-54KU	KT0272	4	M5	34.8	21	4.6	16.8	10
YDS-184KU	KT0273	4	G1/8	41.0	21	6.0	16.8	14
YDS-56KU	KT0274	6	M5	41.6	25	4.6	17.6	12
YDS-186KU	KT0275	6	G1/8	42.4	25	6.0	17.6	14
YDS-146KU	KT0276	6	G1/4	44.4	25	8.0	17.6	17
YDS-188KU	KT0277	8	G1/8	43.7	29	6.0	18.7	14
YDS-148KU	KT0278	8	G1/4	45.7	29	8.0	18.7	17
YDS-388KU	KT0279	8	G3/8	46.7	29	9.0	18.7	20
YDS-1410KU	KT0280	10	G1/4	51.3	35	8.0	19.6	17
YDS-3810KU	KT0281	10	G3/8	52.3	35	9.0	19.6	20
YDS-1210KU	KT0282	10	G1/2	53.3	35	10.0	19.6	24
YDS-3812KU	KT0283	12	G3/8	55.8	41	9.0	21.9	20
YDS-1212KU	KT0284	12	G1/2	56.8	41	10.0	21.9	24

Material: Plastic, nickel-plated brass

Fittings and accessories

Plastic push-in fittings

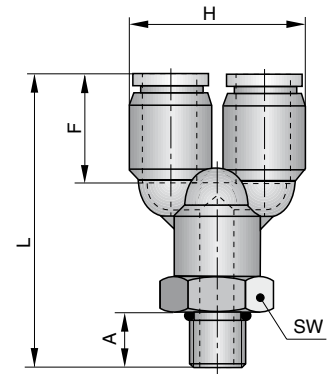

Parallel Y adaptor, swivelling, PTFE-coated male taper thread

Order Instructions Type	Order No.	Tube Ø OD	Port size	L	H	A	F	SW
YDSK-184KU	KT0285	4	R1/8	41.3	21	8	16.8	10
YDSK-186KU	KT0286	6	R1/8	44.1	25	8	17.6	12
YDSK-146KU	KT0287	6	R1/4	47.1	25	10	17.6	14
YDSK-188KU	KT0288	8	R1/8	45.5	29	8	18.7	12
YDSK-148KU	KT0289	8	R1/4	48.5	29	10	18.7	14
YDSK-388KU	KT0290	8	R3/8	48.5	29	11	18.7	17
YDSK-1410KU	KT0291	10	R1/4	54.2	35	10	19.6	14
YDSK-3810KU	KT0292	10	R3/8	56.5	35	11	19.6	17
YDSK-1210KU	KT0293	10	R1/2	58.2	35	14	19.6	22
YDSK-3812KU	KT0294	12	R3/8	58.3	41	11	21.9	17
YDSK-1212KU	KT0295	12	R1/2	62.0	41	14	21.9	22

Material: Plastic, nickel-plated brass

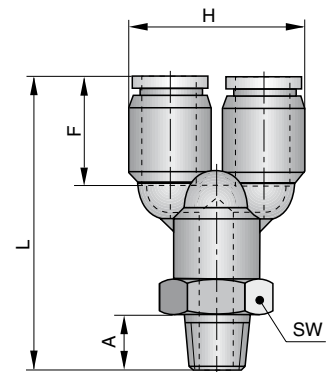

Dimensions in mm

Fittings and accessories

Plastic push-in fittings

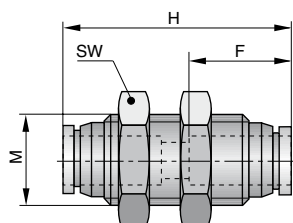
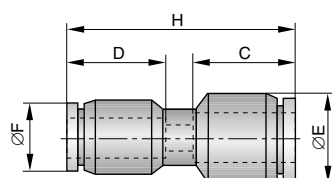
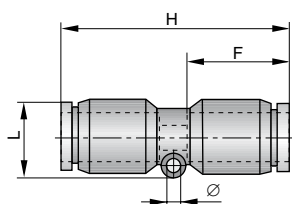

Straight connector

Order Instructions Type	Order No.	Tube Ø OD	H	L	Ø	F
GVS-4KU	KT0296	4	34.6	12.8	3.3	16.3
GVS-6KU	KT0297	6	36.8	14.8	3.3	17.6
GVS-8KU	KT0298	8	39.4	17.8	4.3	18.7
GVS-10KU	KT0299	10	43.2	20.0	4.3	19.6
GVS-12KU	KT0300	12	47.8	23.3	4.3	21.9
GVS-16KU	KT0301	16	51.1	25.8	-	24.0

Material: Plastic

Reducing straight connector

Order Instructions Type	Order No.	Tube Ø OD-A	Tube Ø OD-B	H	C	D	ØE	ØF
GVS-64KU	KT0302	6	4	36.6	17.6	16.8	12.5	10.5
GVS-86KU	KT0303	8	6	37.6	18.7	17.6	14.5	12.5
GVS-108KU	KT0304	10	8	41.0	19.6	18.7	17.5	14.5
GVS-1210KU	KT0305	12	10	44.0	21.9	19.6	20.5	17.5
GVS-1612KU	KT0306	16	12	49.2	24.2	22.9	25.7	20.7

Material: Plastic

Straight bulkhead connector

Order Instructions Type	Order No.	Schlauch Ø DA	H	F	M	SW
SOV-4Msv	KT0307	4	35.1	16.3	M12 x 1	14
SOV-6Msv	KT0308	6	39.4	17.6	M14 x 1	17
SOV-8Msv	KT0309	8	41.8	18.7	M16 x 1	19
SOV-10Msv	KT0310	10	44.0	19.6	M20 x 1	24
SOV-12Msv	KT0311	12	48.8	21.9	M22 x 1	26

Material: nickel-plated brass

Dimensions in mm

Equal elbow connector

Order Instructions		Tube	H	L	Ø	F
Type	Order No.	Ø OD				
WVS-4KU	KT0312	4	23.9	23.9	3.3	16.8
WVS-6KU	KT0313	6	27.0	27.0	3.3	17.6
WVS-8KU	KT0314	8	31.1	31.1	4.3	18.7
WVS-10KU	KT0315	10	34.1	34.1	4.3	19.6
WVS-12KU	KT0480	12	39.1	39.1	4.3	21.9
WVS-16KU	KT0481	16	46.8	46.8	5.3	24.2

Material: Plastic

Stem elbow connector

Order Instructions		A	B	C	D	E	F
Type	Order No.						
WVSN-44KU	KT0482	4	4	18.8	16.8	28.4	22
WVSN-66KU	KT0316	6	6	20.3	17.4	31.4	24
WVSN-88KU	KT0317	8	8	23.0	19.0	34.3	26
WVSN-1010KU	KT0318	10	10	24.2	19.7	37.9	28
WVSN-1212KU	KT0319	12	12	28.0	22.1	41.4	30
WVSN-1616KU	KT0320	16	16	32.0	24.0	48.5	35

Material: Plastic

Equal tee connector

Order Instructions		Tube	H	L	Ø	F
Type	Order No.	Ø OD				
TVS-4KU	KT0321	4	36.6	24.2	3.3	16.3
TVS-6KU	KT0322	6	41.8	27.5	3.3	17.6
TVS-8KU	KT0323	8	44.9	30.7	4.3	18.7
TVS-10KU	KT0324	10	48.2	34.1	4.3	19.6
TVS-12KU	KT0325	12	56.8	39.9	4.3	21.9
TVS-16KU	KT0326	16	68.2	47.2	4.3	24.0

Material: Plastic

Dimensions in mm

Fittings and accessories

Plastic push-in fittings

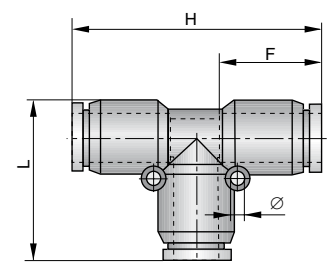
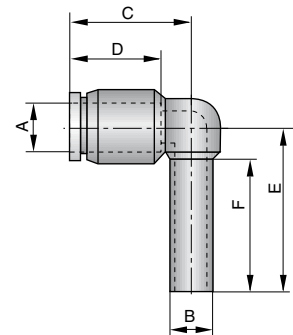
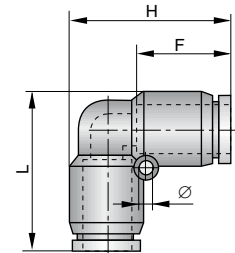

Fittings and accessories

Plastic push-in fittings

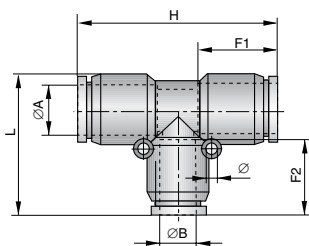

Reducing tee connector

Order Instructions Type	Order No.	Tube Ø OD-A	Tube Ø OD-B	H	L	Ø	F1	F2
TVSR-108KU	KT0468	10	8	49.2	33.5	4.3	19.6	18.7
TVSR-1210KU	KT0469	12	10	56.0	37.6	4.3	21.9	19.6
TVSR-1610KU	KT0470	16	10	60.8	43.1	4.3	24.0	19.6
TVSR-1612KU	KT0471	16	12	63.7	45.5	4.3	24.0	21.9

Material: Plastic

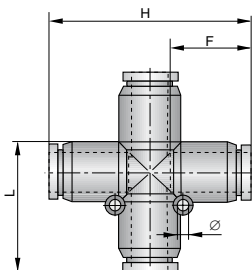

4-way cross connector

Order Instructions Type	Order No.	Tube Ø OD	H	L	Ø	F
KVS-4KU	KT0483	4	36.6	37.9	3.3	16.8
KVS-6KU	KT0327	6	41.8	42.5	4.3	17.6
KVS-8KU	KT0328	8	44.9	46.8	4.3	18.7
KVS-10KU	KT0329	10	48.2	50.5	4.3	19.6
KVS-12KU	KT0330	12	54.8	57.2	4.3	21.9

Material: Plastic

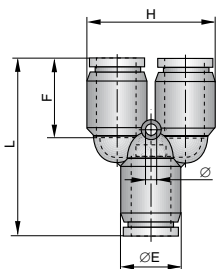

Parallel Y connector

Order Instructions Type	Order No.	Tube Ø OD	H	L	Ø	F	ØE
YVS-4KU	KT0331	4	21	37.1	3.3	16.3	10.5
YVS-6KU	KT0332	6	25	39.9	3.3	17.6	12.5
YVS-8KU	KT0333	8	29	43.4	4.3	18.7	14.5
YVS-10KU	KT0334	10	35	45.5	4.3	19.6	17.5
YVS-12KU	KT0335	12	41	54.8	4.3	21.9	20.5

Material: Plastic

Dimensions in mm

Reducing parallel Y connector

Order Instructions Type	Order No.	Tube Ø OD-A	Tube Ø OD-B	L	H	F-C	F-D	ØE	ØF	Ø
YVSR-64KU	KT0336	6	4	37.9	21	17.6	16.3	12.5	10.5	3.3
YVSR-86KU	KT0337	8	6	41.3	25	18.7	17.6	14.5	12.5	3.3
YVSR-108KU	KT0338	10	8	43.3	29	19.6	18.7	17.5	14.5	4.3
YVSR-1210KU	KT0339	12	10	46.5	35	21.9	19.6	20.5	17.5	4.3

Material: Plastic

Parallel Y stem connector

Order Instructions Type	Order No.	Tube Ø OD	Stem Ø	J	H	L	F
YVSN-44KU	KT0340	4	4	22	21	49.5	16.8
YVSN-66KU	KT0341	6	6	24	25	54.7	17.6
YVSN-88KU	KT0342	8	8	26	29	59.8	18.7
YVSN-1010KU	KT0343	10	10	28	35	66.1	19.6
YVSN-1212KU	KT0344	12	12	30	41	71.6	21.9

Material: Plastic

Reducing straight stem connector

Order Instructions Type	Order No.	A	B	C	D	F
R-64KU	KT0345	6	4	21.7	41.0	12.8
R-84KU	KT0346	8	4	22.7	42.0	12.8
R-86KU	KT0347	8	6	23.7	44.3	13.4
R-106KU	KT0348	10	6	28.7	47.3	13.4
R-108KU	KT0349	10	8	27.7	49.7	14.2
R-128KU	KT0350	12	8	30.7	52.5	14.2
R-1210KU	KT0351	12	10	31.2	56.5	14.9

Material: Plastic

Dimensions in mm

Fittings and accessories

Plastic push-in fittings

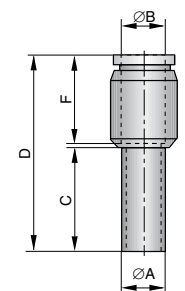
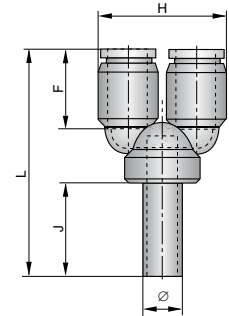
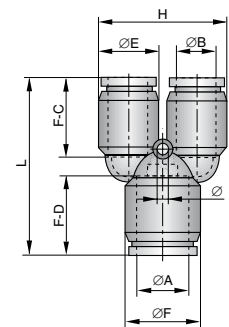

Fittings and accessories

Plastic push-in fittings

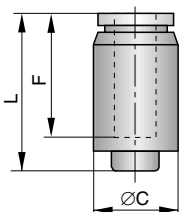
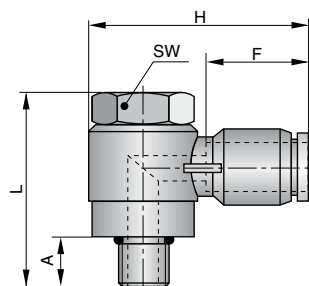
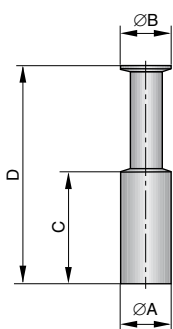

Blanking plug, black

Order Instructions		A	B	C	D
Type	Order No.				
VST-4KU	KT0352	4	4	17.7	30
VST-6KU	KT0353	6	6	19.4	34
VST-8KU	KT0354	8	8	21.2	38
VST-10KU	KT0355	10	10	23.8	42
VST-12KU	KT0356	12	12	29.5	46

Material: Plastic

Banjo elbow adaptor, male parallel thread with O-ring

Order Instructions		Tube Ø OD	Port size	L	H	A	F	SW
Type	Order No.							
ESS-54KU	KT0357	4	M5	22.1	26.6	4.6	16.8	8
ESS-184KU	KT0358	4	G1/8	23.5	32.4	4.5	16.3	8
ESS-56KU	KT0359	6	M5	22.1	27.2	4.6	17.6	8
ESS-186KU	KT0360	6	G1/8	23.5	33.5	4.5	17.6	8
ESS-146KU	KT0361	6	G1/4	28.0	37.3	6.0	17.6	12
ESS-188KU	KT0362	8	G1/8	23.5	34.2	4.5	18.7	8
ESS-148KU	KT0363	8	G1/4	28.0	38.3	6.0	18.7	12
ESS-388KU	KT0364	8	G3/8	32.5	41.8	6.0	18.7	14
ESS-3810KU	KT0365	10	G3/8	32.5	42.5	6.0	19.6	14
ESS-1210KU	KT0366	10	G1/2	34.0	48.6	7.5	19.6	19
ESS-3812KU	KT0367	12	G3/8	32.5	44.8	6.0	21.9	14
ESS-1212KU	KT0368	12	G1/2	34.0	50.3	7.5	21.9	19

Material: Plastic, nickel-plated brass

End cap

Order Instructions		Tube Ø OD	C	L	F
Type	Order No.				
VK-4KU	KT0472	4	10.5	18.0	16.8
VK-6KU	KT0473	6	12.5	19.0	17.6
VK-8KU	KT0474	8	14.5	21.0	18.7
VK-10KU	KT0475	10	17.5	23.0	19.6
VK-12KU	KT0476	12	19.5	25.0	21.9
VK-16KU	KT0477	16	25.5	27.5	24.0

Material: Plastic

Dimensions in mm

Triple tee connector

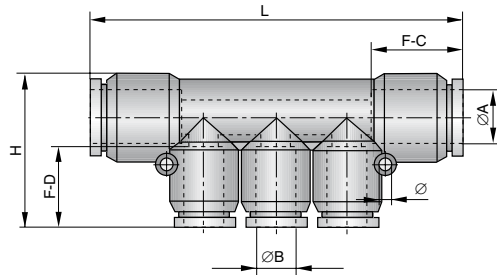

Order Instructions		Tube	Tube	Ø	H	L	F-C	F-D
Type	Order No.	Ø OD-A	Ø OD-B					
VVS-64KU	KT0369	6	4	3.3	24.2	63.7	17.6	16.3
VVS-84KU	KT0370	8	4	4.3	28.5	65.7	18.7	16.3
VVS-86KU	KT0371	8	6	4.3	34.0	71.7	18.7	17.6
VVS-106KU	KT0372	10	6	4.3	32.0	78.1	19.6	17.6
VVS-108KU	KT0373	10	8	4.3	34.5	83.4	19.6	18.7

Material: Plastic

Fittings and accessories

Plastic push-in fittings



Triple run tee adaptor, swivelling, male parallel thread with O-ring

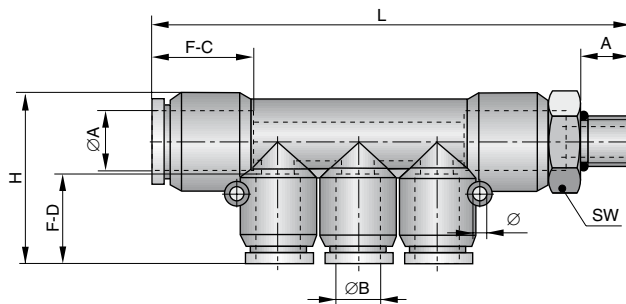

Order Instructions		Tube	Tube	Port	Ø	H	L	F-C	F-D	A	SW
Type	Order No.	Ø OD-A	Ø OD-B	size							
VDS-18-64KU	KT0374	6	4	G1/8	3.3	24.2	70.1	17.6	16.3	6	14
VDS-14-84KU	KT0375	8	4	G1/4	4.3	28.5	74.9	18.7	16.3	8	17
VDS-14-86KU	KT0376	8	6	G1/4	4.3	34.0	80.0	18.7	17.6	8	17
VDS-38-108KU	KT0377	10	8	G3/8	4.3	34.5	92.3	19.6	18.7	8	20

Material: Plastic, nickel-plated brass



Dimensions in mm

Fittings and accessories

Miniature plastic push-in fittings

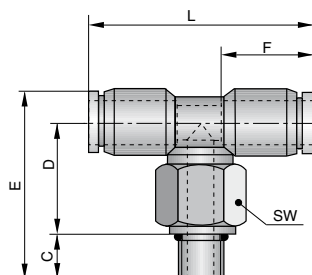
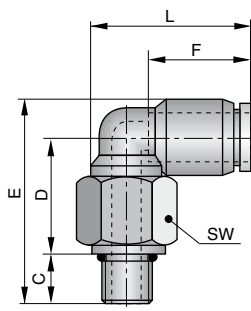
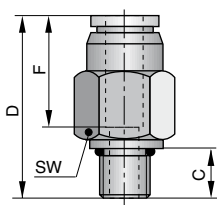

Straight adaptor, male parallel thread with O-ring

Order Instructions Type	Order No.	Tube Ø OD	Port size	C	D	F	SW
GSM-33Msv	KT0378	3	M3	4.0	17.1	11.1	7
GSM-53Msv	KT0379	3	M5	4.6	17.7	11.1	8
GSM-63Msv	KT0380	3	M6	5.1	18.2	11.1	8
GSM-34Msv	KT0381	4	M3	4.0	17.7	11.6	8
GSM-54Msv	KT0382	4	M5	4.6	18.2	11.6	8
GSM-64Msv	KT0383	4	M6	5.1	18.8	11.6	8
GSM-184Msv	KT0384	4	G1/8	6.0	18.0	11.6	12
GSM-56Msv	KT0385	6	M5	4.6	19.4	12.8	10
GSM-66Msv	KT0386	6	M6	5.1	19.9	12.8	10
GSM-186Msv	KT0387	6	G1/8	6.0	18.6	12.8	12

Material: Nickel-plated brass

Elbow adaptor, swivelling, male parallel thread with O-ring

Order Instructions Type	Order No.	Tube Ø OD	Port size	C	D	E	L	F	SW
LDSM-33KU	KT0388	3	M3	3.0	13.0	19.8	17.2	11.1	8
LDSM-53KU	KT0389	3	M5	3.6	13.0	20.4	17.2	11.1	8
LDSM-63KU	KT0390	3	M6	4.1	13.0	20.9	17.2	11.1	8
LDSM-34KU	KT0391	4	M3	3.0	13.0	20.3	18.2	11.6	8
LDSM-54KU	KT0392	4	M5	3.6	13.0	20.9	18.2	11.6	8
LDSM-64KU	KT0393	4	M6	4.1	13.0	21.4	18.2	11.6	8
LDSM-184KU	KT0394	4	G1/8	6.0	12.2	21.2	21.5	11.6	14
LDSM-56KU	KT0395	6	M5	3.6	13.0	21.9	19.4	12.8	8
LDSM-66KU	KT0396	6	M6	4.1	13.0	22.4	19.4	12.8	8
LDSM-186KU	KT0397	6	G1/8	6.0	12.2	22.6	23.2	12.8	14

Material: Plastic, nickel-plated brass

Elbow adaptor, swivelling, male parallel thread with O-ring

Order Instructions Type	Order No.	Tube Ø OD	Port size	C	D	E	L	F	SW
TDSM-33KU	KT0398	3	M3	3.0	13.0	19.8	26.6	11.1	8
TDSM-53KU	KT0399	3	M5	3.6	13.0	20.4	26.6	11.1	8
TDSM-63KU	KT0400	3	M6	4.1	13.0	20.9	26.6	11.1	8
TDSM-34KU	KT0401	4	M3	3.0	13.0	20.3	28.6	11.6	8
TDSM-54KU	KT0402	4	M5	3.6	13.0	20.9	28.6	11.6	8
TDSM-64KU	KT0403	4	M6	4.1	13.0	21.4	28.6	11.6	8
TDSM-184KU	KT0404	4	G1/8	6.0	12.2	21.4	28.6	11.6	14
TDSM-56KU	KT0405	6	M5	3.6	13.0	21.9	31.0	12.8	8
TDSM-66KU	KT0406	6	M6	4.1	13.0	22.4	31.0	12.8	8
TDSM-186KU	KT0407	6	G1/8	6.0	12.2	22.2	31.0	12.8	14

Material: Plastic, nickel-plated brass

Dimensions in mm

Straight connector

Order Instructions Type	Order No.	Tube Ø OD	B	F	H
GVSM-3KU	KT0408	3	7.6	11.1	23.2
GVSM-4KU	KT0409	4	8.5	11.6	26.1
GVSM-6KU	KT0410	6	10.7	12.8	26.6

Material: Plastic

Equal elbow connector

Order Instructions Type	Order No.	Tube Ø OD	B	C	Ø	F	H
WVSM-3KU	KT0411	3	5.4	5.4	3.2	11.1	17.1
WVSM-4KU	KT0412	4	5.8	5.8	3.2	11.6	18.5
WVSM-6KU	KT0413	6	6.9	6.9	3.2	12.8	21.8

Material: Plastic

Equal tee connector

Order Instructions Type	Order No.	Tube Ø OD	Ø	L	F	H
TVSM-3KU	KT0414	3	3.2	17.1	11.1	26.6
TVSM-4KU	KT0415	4	3.2	18.5	11.6	28.6
TVSM-6KU	KT0416	6	3.2	21.8	12.8	33.0

Material: Plastic

Fittings and accessories

Miniature plastic push-in fittings

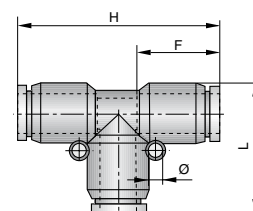
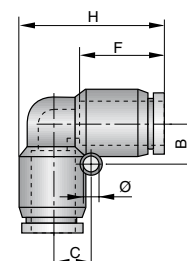
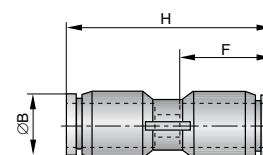

Dimensions in mm

Contents

Description	Page
Characteristics	88
Straight adaptors	89
Elbow adaptors	90–93
Banjo elbow adaptors	90–93
Connectors	94–95
Banjo bolts	96, 97
Banjo elbow bodies	92

Fittings and accessories

Compression fittings

Proven connection system with guide cone and compression nut



Fittings and accessories

Compression fittings

Proven connection system with guide cone and compression nut

- Nickel-plated brass for optimum surface protection
- Tube clamped on its outside diameter by compression nut
- Tube sealed on its inner diameter by cone
- Thread sealed by integrated O-ring
- Thread sealed by integrated O-ring (no seal rings required)

Characteristics

Characteristics	Symbol	Unit	Description
Connecting thread*			M5, G1/8, G1/4, G3/8, G1/2 (parallel and taper)
Tubing outside/inside diameter**		mm	4/2,7, 5/3, 6/4, 8/6, 10/8, 12/10, 15/12,5
Material			
- Body and nut			Nickel-plated brass
- O-ring			Buna N (NBR)
Operating pressure range	$p_{min/max}$	bar	0 to 10 / 0 to 18 (depending on type)
Temperature range	$T_{min/max}$	°C	-25 to +80 / -10 to +60 (depending on type) (other temperature ranges on request)
Medium			Compressed air (other media on request)

* depending on type

** exceptions on some types are specified

Tubing recommendations¹⁾

Tubing type	Compressed air tubing
Tubing material	PU, PA, PE, PVC (glassfibre-reinforced) depending on application

¹⁾ see our range of tubing in section on tubing and hoses, pages 114, 115

Function

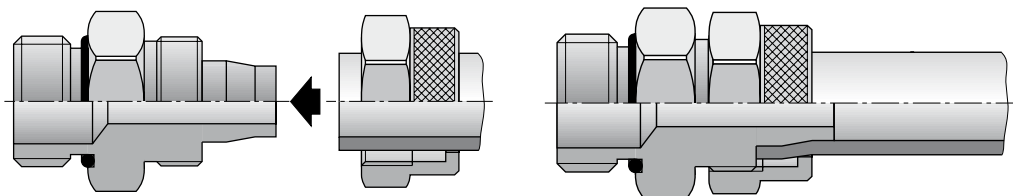

Dimensions in mm

Straight adaptor, male parallel thread with O-ring

Order Instructions Type	Order No.	Nominal size	ØD	G	B	L	SW1	SW2
G-54Msv	KW 0178	2	4/2.7	M5	4.0	20	8	8
G-55Msv	KW 0181	2.2	5/3	M5	4.0	20	8	8
G-185Msv	KW 0182	2.2	5/3	G1/8	6.0	23.0	8	15
G-56Msv	KW 0183	3.0	6/4	M5	6.0	25.5	12	13
G-186Msv	KW 0184	3.0	6/4	G1/4	8.0	28.0	12	16
G-146Msv	KW 0185	3.0	6/4	G3/8	9.0	29.0	12	19
G-188Msv	KW 0186	5.0	8/6	G1/8	6.0	25.5	14	14
G-148Msv	KW 0187	5.0	8/6	G1/4	8.0	28.0	14	16
G-388Msv	KW 0188	5.0	8/6	G3/8	9.0	29.0	14	19
G-1410Msv	KW 0189	6.5	10/8	G1/4	8.0	29.5	16	16
G-3810Msv	KW 0190	6.5	10/8	G3/8	9.0	30.5	16	19
G-1210Msv	KW 0191	6.5	10/8	G1/2	10.0	32.0	16	24
G-3812Msv	KW 0192	8.5	12/10	G3/8	9.0	32.0	18	19
G-1212Msv	KW 0193	8.5	12/10	G1/2	10.0	33.5	18	24
G-1215Msv	KW 0194	11	15/12.5	G1/2	10.0	35.5	22	24

Straight adaptor for metal-braided tubing, male parallel thread with O-ring

Order Instructions Type	Order No.	Nominal size	Tube Ø OD/ID	G	SW	I	L ₁	L ₂
G-146M	KX 5517	5.2	9/6	G1/4	17	9	35.0	20.5
G-149M	KX 5518	7.5	12/9	G1/4	22	9	38.0	23.0
G-386M	KX 5519	5.2	9/6	G3/8	19	9	35.0	20.5
G-389M	KX 5520	7.5	12/9	G3/8	22	9	38.0	23.0
G-126M	KX 5521	5.2	9/6	G1/2	24	11	37.5	20.5
G-129M	KX 5522	7.5	12/9	G1/2	24	11	40.0	23.0

Werkstoff: Aluminium schwarz eloxiert

Straight adaptor, male taper thread

Order Instructions Type	Order No.	Nominal size	ØD	R tap.	I	H	SW1	SW2
GK-185Msv	KW 0166	2.2	5/3	R1/8	8.0	25.0	8	12
GK-186Msv	KW 0167	3.0	6/4	R1/8	8.0	27.5	12	12
GK-146Msv	KW 0168	3.0	6/4	R1/4	11.0	31.0	12	14
GK-188Msv	KW 0169	5.0	8/6	R1/8	8.0	27.5	14	12
GK-148Msv	KW 0170	5.0	8/6	R1/4	11.0	31.0	14	14
GK-388Msv	KW 0171	5.0	8/6	R3/8	11.5	31.5	14	17
GK-1810Msv	KW 0838	6.5	10/8	R1/8	8.0	29.5	16	14
GK-1410Msv	KW 0172	6.5	10/8	R1/4	11.0	32.5	16	14
GK-3810Msv	KW 0173	6.5	10/8	R3/8	11.5	33.0	16	17
GK-1210Msv	KW 0174	6.5	10/8	R1/2	14.0	36.0	16	22
GK-3812Msv	KW 0175	8.5	12/10	R3/8	11.5	34.5	18	17
GK-1212Msv	KW 0176	8.5	12/10	R1/2	14.0	37.5	18	22
GK-1215Msv	KW 0177	11.0	15/12.5	R1/2	14.0	39.5	22	22

Dimensions in mm

Fittings and accessories

Compression fittings

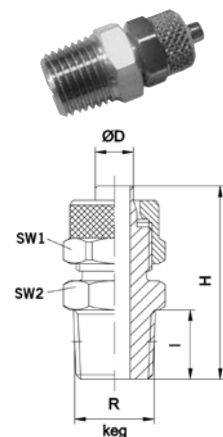
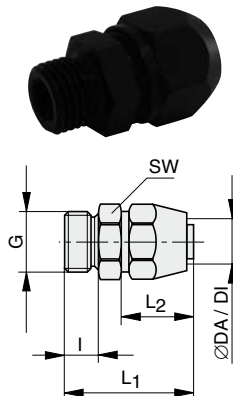
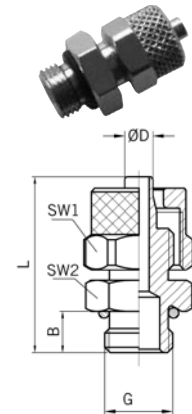

Fittings and accessories

Compression fittings

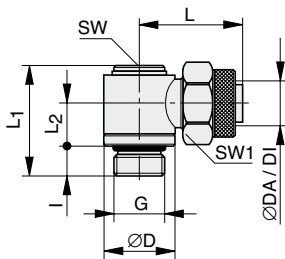
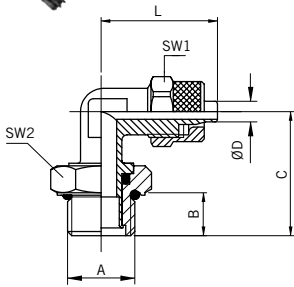
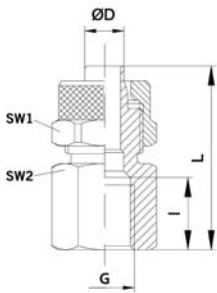

Pressure gauge adaptor

Order Instructions Type	Order No.	Nominal size	ØD	G	I	L	SW1	SW2
MV-186Msv	KW 0195	3.0	6/4	G1/8	8.0	25.0	12	14
MV-146Msv	KW 0196	3.0	6/4	G1/4	11.0	29.0	12	17
MV-188Msv	KW 0197	5.0	8/6	G1/8	8.0	25.0	14	14
MV-148Msv	KW 0198	5.0	8/6	G1/4	11.0	29.0	14	17
MV-388Msv	KW 0199	5.0	8/6	G3/8	11.5	29.5	14	20
MV-1410Msv	KW 0200	6.5	10/8	G1/4	11.0	30.5	16	17
MV-3810Msv	KW 0201	6.5	10/8	G3/8	11.5	31.0	16	20
MV-1210Msv	KW 0202	6.5	10/8	G1/2	14.0	34.5	16	24

Elbow adaptor, swivelling, male parallel thread with O-ring

Order Instructions Type	Order No.	Nominal size	ØD	A	B	C	L	SW1	SW2
LD-186Msv	KW 0964	3.0	6/4	G1/8	6.0	22.5	22.5	12	14
LD-146Msv	KW 0965	3.0	6/4	G1/4	8.0	25.0	23.5	12	17
LD-188Msv	KW 0966	5.0	8/6	G1/8	6.0	22.5	23.5	14	14
LD-148Msv	KW 0967	5.0	8/6	G1/4	8.0	25.0	23.5	14	17
LD-1410Msv	KW 0968	6.5	10/8	G1/4	8.0	25.5	25.5	16	17

For frequent swivelling see Type ES...

Banjo elbow adaptor, male parallel thread with O-ring

Order Instructions Type	Order No.	Nominal size	Ø DA/DI	G	SW	SW1	ØD	I	L	L ₁	L ₂
ES-54Msv	KW 0323	1.5	4.0/2.0	M5	2	9	9.9	4	20.0	16.8	6.5
ES-185Msv	KW 0325	2.0	5.0/3.0	G1/8	5	8	15.0	6	17.0	27.0	10.5
ES-56Msv	KW 0326	3.0	6.0/4.0	M5	2	9	9.9	4	20.5	16.8	6.5
ES-186Msv	KW 0327	3.0	6.0/4.0	G1/8	5	12	15.0	6	24.0	27.0	10.5
ES-146Msv	KW 0328	3.0	6.0/4.0	G1/4	6	12	18.0	8	26.5	31.5	11.5
ES-188Msv	KW 0329	5.0	8.0/6.0	G1/8	5	14	15.0	6	24.0	27.0	10.5
ES-148Msv	KW 0330	5.0	8.0/6.0	G1/4	6	14	18.0	8	26.0	31.5	11.5
ES-388Msv	KW 0331	5.0	8.0/6.0	G3/8	6	14	21.0	9	28.0	36.0	13.5
ES-1410Msv	KW 0332	6.8	10.0/8.0	G1/4	6	16	18.0	8	28.0	31.5	11.5
ES-3810Msv	KW 0333	6.8	10.0/8.0	G3/8	6	16	21.0	9	29.0	36.0	13.5
ES-1210Msv	KW 0334	6.8	10.0/8.0	G1/2	10	16	26.0	11	30.5	32.0	15.5
ES-3812Msv	KW 0335	8.5	12.0/10.0	G3/8	6	19	21.0	9	31.5	36.0	13.5
ES-1212Msv	KW 0336	8.5	12.0/10.0	G1/2	10	19	26.0	11	33.0	42.0	15.5
ES-1215Msv	KW 0829	11.0	15.0/12.5	G1/2	10	22	26.0	11	35.0	42.0	15.5

Application: for frequent swivelling

Dimensions in mm

Banjo elbow adaptor for metal-braided tubing, male parallel thread with O-ring

Order Instructions Type	Order No.	Nominal size	Tube ØOD/ID	G	B	I	L ₁	L ₂	L ₃	L ₄	SW
ES-146M	KX 5540	5.2	9/6	G1/4	20	8	37	14.0	30.0	39.5	17
ES-149M	KX 5541	6.5	12/9	G1/4	22	8	40	15.5	32.5	42.0	17
ES-389M	KX 5542	7.0	12/9	G3/8	24	8	41	15.5	35.0	47.0	22

Material: aluminum, black-anodized

Elbow adaptor, male taper thread

Order Instructions Type	Order No.	Nominal size	ØD	R tap.	B	C	L	SW1	SW2
WE-185Msv	KW 0215	2.2	5/3	R1/8	8.0	17.0	21.5	8	8
WE-186Msv	KW 0216	3.0	6/4	R1/8	8.0	17.0	22.5	12	8
WE-146Msv	KW 0217	3.0	6/4	R1/4	11.0	20.0	22.5	12	10
WE-188Msv	KW 0218	5.0	8/6	R1/8	8.0	17.0	22.5	14	10
WE-148Msv	KW 0219	5.0	8/6	R1/4	11.0	20.0	22.5	14	10
WE-388Msv	KW 0220	5.0	8/6	R3/8	11.5	22.5	24.0	14	11
WE-1810Msv	KW 0874	6.5	10/8	R1/8	8.0	18.5	25.5	16	11
WE-1410Msv	KW 0221	6.5	10/8	R1/4	11.0	21.5	25.5	16	11
WE-3810Msv	KW 0222	6.5	10/8	R3/8	11.5	22.5	25.5	16	11
WE-1210Msv	KW 0223	6.5	10/8	R1/2	14.0	28.0	28.0	16	17
WE-3812Msv	KW 0224	8.5	12/10	R3/8	11.5	24.5	30.0	18	14
WE-1212Msv	KW 0225	8.5	12/10	R1/2	14.0	28.0	30.5	18	17
WE-1215Msv	KW 0226	11.0	15/12.5	R1/2	14.0	28.0	34.0	22	17

Elbow adaptor, female parallel thread

Order Instructions Type	Order No.	Nominal size	ØD	G	B	C	L	SW1	SW2
WI-185Msv	KW 0963	2.2	5/3	G1/8	8.0	19.0	21.5	8	10
WI-186Msv	KW 0227	3.0	6/4	G1/8	8.0	19.0	22.5	12	10
WI-146Msv	KW 0228	3.0	6/4	G1/4	10.5	23.0	25.0	12	11
WI-188Msv	KW 0229	5.0	8/6	G1/8	8.0	19.0	22.5	14	10
WI-148Msv	KW 0230	5.0	8/6	G1/4	10.5	23.0	25.0	14	11
WI-1410Msv	KW 0231	6.5	10/8	G1/4	11.0	23.5	26.0	16	13

Dimensions in mm

Fittings and accessories

Compression fittings

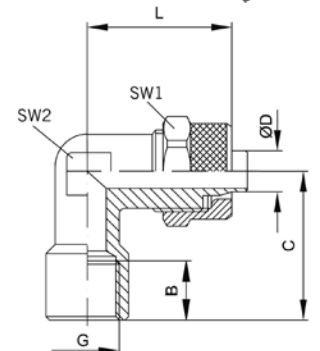
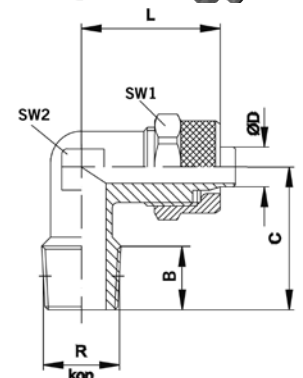
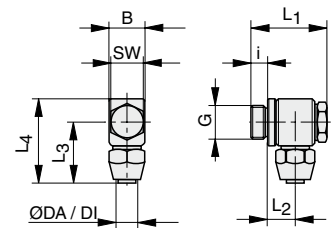

Fittings and accessories

Compression fittings

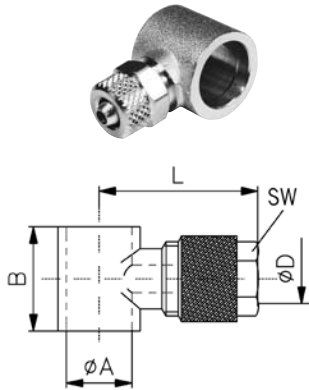

Banjo elbow body, for banjo bolt*

Order Instructions Type	Order No.	ØD	ØA for banjo bolt	B	L	SW
RE-54Msv	KW 0270	4/2.7	M5	9.0	16.0	8
RE-55Msv	KW 0274	5/3	M5	9.0	15.5	8
RE-185Msv	KW 0275	5/3	G1/8	15.0	23.0	8
RE-56Msv	KW 0276	6/4	M5	9.0	16.5	9
RE-186Msv	KW 0277	6/4	G1/8	15.0	23.0	10
RE-146Msv	KW 0278	6/4	G1/4	17.0	26.0	10
RE-188Msv	KW 0279	8/6	G1/8	15.0	23.0	12
RE-148Msv	KW 0280	8/6	G1/4	17.0	26.0	12
RE-388Msv	KW 0281	8/6	G3/8	20.0	26.0	12
RE-1410Msv	KW 0282	10/8	G1/4	17.0	29.5	14
RE-3810Msv	KW 0283	10/8	G3/8	20.0	30.5	14
RE-1210Msv	KW 0284	10/8	G1/2	24.0	34.0	14
RE-3812Msv	KW 0285	12/10	G3/8	20.0	31.5	15
RE-1212Msv	KW 0286	12/10	G1/2	24.0	35.0	15
RE-1215Msv	KW 0287	15/12.5	G1/2	24.0	36.5	22

* for banjo bolts see pages 96, 97

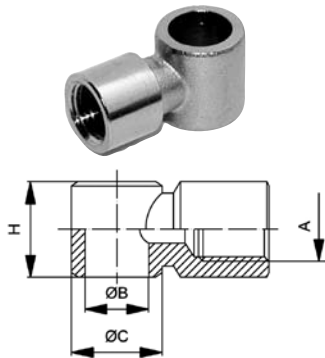

Banjo elbow body, female parallel thread, for banjo bolt*

Order Instructions Type	Order No.	A	ØB for banjo bolt	ØC	H
REI-1818Msv	KW 0346	G1/8	10.0	14	15.0
REI-1414Msv	KW 0347	G1/4	13.3	18	17.0
REI-3838Msv	KW 0348	G3/8	17.0	21	20.0

* for banjo bolts see pages 96, 97

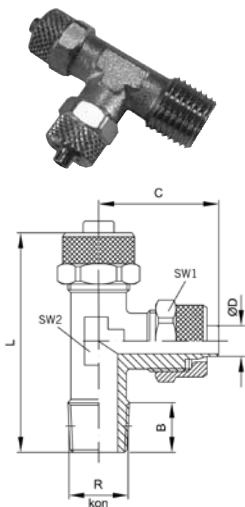

Run tee adaptor, male taper thread

Order Instructions Type	Order No.	Nominal size	ØD	R tap.	B	C	L	SW1	SW2
LE-185Msv	KW 0250	2.2	5/3	R1/8	8.0	21.5	38.5	8	8
LE-186Msv	KW 0251	3.0	6/4	R1/8	8.0	22.5	39.5	12	8
LE-146Msv	KW 0252	3.0	6/4	R1/4	11.0	22.5	42.5	12	10
LE-188Msv	KW 0253	5.0	8/6	R1/8	8.0	22.5	40.5	14	10
LE-148Msv	KW 0254	5.0	8/6	R1/4	11.0	22.5	43.5	14	10
LE-388Msv	KW 0255	5.0	8/6	R3/8	11.5	23.5	46.5	14	11
LE-1410Msv	KW 0256	6.5	10/8	R1/4	11.0	25.5	46.5	16	11
LE-3810Msv	KW 0257	6.5	10/8	R3/8	11.5	25.5	48.0	16	11
LE-1210Msv	KW 0258	6.5	10/8	R1/2	14.0	29.0	57.0	16	17
LE-3812Msv	KW 0259	8.5	12/10	R3/8	11.5	30.0	54.5	18	14
LE-1212Msv	KW 0260	8.5	12/10	R1/2	14.0	30.5	58.5	18	17

Dimensions in mm

Banjo tee adaptor, male parallel thread with O-ring

Order Instructions		ØD	A	B	S	L	SW1	SW2
Type	Order No.							
TS-186Msv	KW 0337	6/4	G1/8	6.0	28.0	46.6	14	10
TS-146Msv	KW 0338	6/4	G1/4	8.0	33.0	50.0	17	10
TS-188Msv	KW 0339	8/6	G1/8	6.0	28.0	50.0	14	12
TS-148Msv	KW 0340	8/6	G1/4	8.0	33.0	55.0	17	12
TS-388Msv	KW 0341	8/6	G3/8	9.5	37.0	55.4	22	12
TS-1410Msv	KW 0342	10/8	G1/4	8.0	33.0	59.0	17	14
TS-3810Msv	KW 0343	10/8	G3/8	9.0	37.0	61.0	22	14
TS-3812Msv	KW 0345	12/10	G3/8	9.5	37.0	63.0	22	15

Application: for frequent swivelling

Branch tee adaptor, male taper thread

Order Instructions		Nominal size	ØD	R tap.	B	C	L	SW1	SW2
Type	Order No.								
TE-185Msv	KW 0238	2.2	5/3	R1/8	8.0	17.0	43.0	8	8
TE-186Msv	KW 0239	3.0	6/4	R1/8	8.0	17.0	45.0	11	8
TE-146Msv	KW 0240	3.0	6/4	R1/4	11.0	20.5	45.5	11	10
TE-188Msv	KW 0241	5.0	8/6	R1/8	8.0	17.5	45.5	14	10
TE-148Msv	KW 0242	5.0	8/6	R1/4	11.0	20.5	45.5	14	10
TE-388Msv	KW 0243	5.0	8/6	R3/8	11.5	21.5	48.0	14	11
TE-1410Msv	KW 0244	6.5	10/8	R1/4	11.0	21.5	51.0	16	11
TE-3810Msv	KW 0245	6.5	10/8	R3/8	11.5	22.5	51.0	16	11
TE-1210Msv	KW 0246	6.5	10/8	R1/2	14.0	28.0	57.0	16	17
TE-3812Msv	KW 0247	8.5	12/10	R3/8	11.5	22.5	60.0	18	14
TE-1212Msv	KW 0248	8.5	12/10	R1/2	14.0	28.0	61.0	18	17
TE-1215Msv	KW 0249	11.0	15/12.5	R1/2	14.0	28.0	68.0	22	17

Banjo tee body, for banjo bolt*

Order Instructions		ØD	ØA for banjo bolt	B	L	SW
Type	Order No.					
RD-185Msv	KW 0288	5/3	G1/8	15.0	46.6	8
RD-186Msv	KW 0289	6/4	G1/8	15.0	46.6	10
RD-146Msv	KW 0290	6/4	G1/4	17.0	50.6	10
RD-188Msv	KW 0291	8/6	G1/8	15.0	50.0	12
RD-148Msv	KW 0292	8/6	G1/4	17.0	55.0	12
RD-388Msv	KW 0293	8/6	G3/8	20.0	55.4	12
RD-1410Msv	KW 0294	10/8	G1/4	17.0	59.0	14
RD-3810Msv	KW 0295	10/8	G3/8	20.0	61.0	14
RD-1210Msv	KW 0296	10/8	G1/2	24.0	68.0	14
RD-1212Msv	KW 0297	12/10	G1/2	24.0	70.0	15

* for banjo bolts see pages 96, 97

Dimensions in mm

Fittings and accessories

Compression fittings

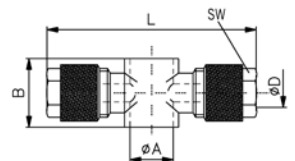
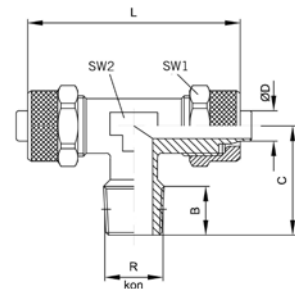
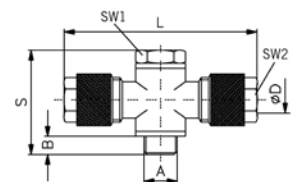

Fittings and accessories

Compression fittings

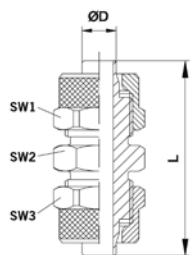

Straight connector

Order Instructions Type	Order No.	Nominal size	ØD	L	SW1	SW2	SW3
GV-5Msv	KW 0203	2.2	5/3	28.5	8	8	8
GV-6Msv	KW 0204	3.0	6/4	34.5	12	12	12
GV-8Msv	KW 0205	5.0	8/6	35.0	14	14	14
GV-10Msv	KW 0206	6.5	10/8	38.0	16	16	14
GV-12Msv	KW 0207	8.5	12/10	41.0	18	17	16
GV-15Msv	KW 0208	11.0	15/12.5	45.5	22	22	22

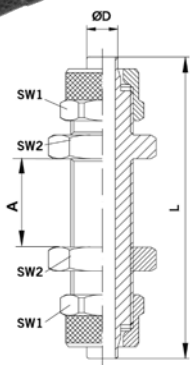

Straight bulkhead connector

Order Instructions Type	Order No.	Nominal size	ØD	Amax	L	SW1	SW2
SV-53Msv	KW 0209	2.2	5/3	8.5	40.0	8	9
SV-64Msv	KW 0210	3.0	6/4	10.5	48.0	12	14
SV-86Msv	KW 0211	5.0	8/6	10.5	48.0	14	16
SV-108Msv	KW 0212	6.5	10/8	8.5	50.0	16	17
SV-1210Msv	KW 0213	8.5	12/10	8.5	53.0	18	19
SV-1512Msv	KW 0214	11.0	15/12.5	8.5	58.0	22	24

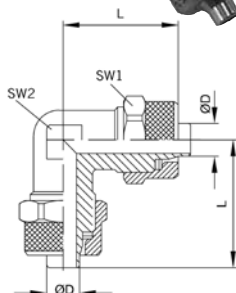
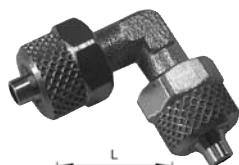

Equal elbow connector

Order Instructions Type	Order No.	Nominal size	ØD	L	SW1	SW2
W-5Msv	KW 0232	2.2	5/3	21.5	8	8
W-6Msv	KW 0233	3.0	6/4	21.5	12	8
W-8Msv	KW 0234	5.0	8/6	22.5	14	10
W-10Msv	KW 0235	6.5	10/8	25.5	16	11
W-12Msv	KW 0236	8.5	12/10	30.0	18	14
W-15Msv	KW 0237	11.0	15/12.5	34.0	22	17

Dimensions in mm

Equal tee connector

Order Instructions Type	Order No.	Nominal size	ØD	C	L	SW1	SW2
TV-5Msv	KW 0261	2.2	5/3	21.5	43.0	8	8
TV-6Msv	KW 0262	3.0	6/4	22.5	45.0	12	8
TV-8Msv	KW 0263	5.0	8/6	22.5	45.0	12	10
TV-10Msv	KW 0264	6.5	10/8	25.5	51.0	16	11
TV-12Msv	KW 0265	8.5	12/10	30.0	60.0	18	14
TV-15Msv	KW 0266	11.0	15/12.5	34.0	68.0	22	17

4-way cross connector

Order Instructions Type	Order No.	Nominal size	ØD	L	SW1	SW2
KV-6Msv	KW 0267	3.0	6/4	45.0	12	8
KV-8Msv	KW 0268	5.0	8/6	45.0	14	10
KV-10Msv	KW 0269	6.5	10/8	51.0	16	11

Single banjo bolt, male parallel thread, for banjo bodies*

Order Instructions Type	Order No.	A	B	C	L	SW
H-118Msv	KW 0299	G1/8	8.5	15.0	28.0	14
H-114Msv	KW 0300	G1/4	12.0	18.0	33.0	17
H-138Msv	KW 0301	G3/8	13.0	21.0	36.0	19
H-112Msv	KW 0302	G1/2	15.0	23.5	42.0	24

* for banjo bodies see page 92, 93

Delivery includes: 1 banjo body, 2 sealing rings

Dimensions in mm

Fittings and accessories

Compression fittings

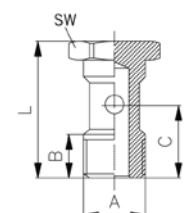
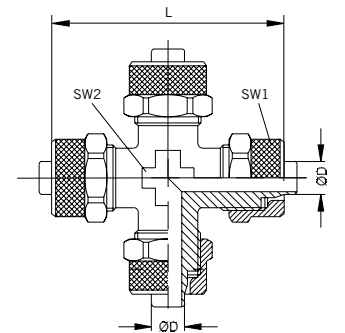
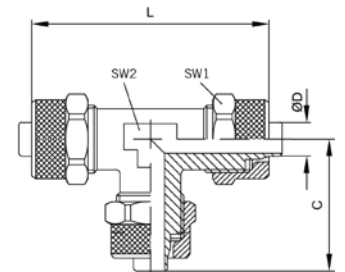

Fittings and accessories

Compression fittings

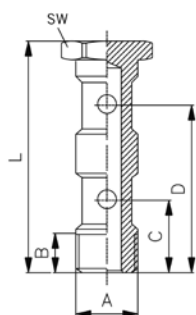

Double banjo bolt , male parallel thread, for banjo bodies*

Order Instructions		A	B	C	D	L	SW
Type	Order No.						
H-218Msv	KW 0307	G1/8	9.0	15.0	31.0	44.5	14
H-214Msv	KW 0308	G1/4	11.0	17.0	36.0	51.5	17
H-238Msv	KW 0309	G3/8	14.0	20.5	43.0	58.1	19
H-212Msv	KW 0310	G1/2	15.5	23.5	49.5	68.0	24

* for banjo bodies see pages 92, 93

Delivery includes: 1 banjo body, 3 sealing rings

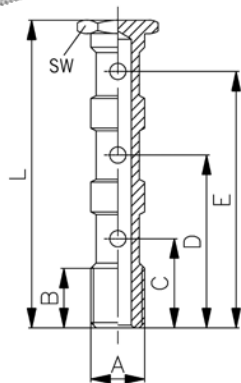

Triple banjo bolt, male parallel thread, for banjo bodies*

Order Instructions		A	B	C	D	E	L	SW
Type	Order No.							
H-318Msv	KW 0972	G1/8	10.5	16.0	32.5	48.0	60	14
H-314Msv	KW 0973	G1/4	12.0	16.5	33.0	48.5	62	17

* for banjo bodies see pages 92, 93

Delivery includes: 1 banjo body, 4 sealing rings

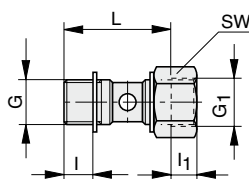

Single hollow bolt with internal thread – for L-banjo's*

Order Instructions		G	G ₁	SW	I	I ₁	L
Type	Order No.						
HI-118Msv	KW 0303	G1/8	G1/8	14	6	7	36.5
HI-114Msv	KW 0304	G1/4	G1/4	17	8	8	42.5
HI-138Msv	KW 0305	G3/8	G3/8	20	9	10	49.5
HI-112Msv	KW 0306	G1/2	G1/2	27	10	11	56.5

* for banjo bodies see pages 92, 93

Delivery includes: 1 banjo body, 2 sealing rings

Dimensions in mm

Double banjo bolt, female parallel thread, for banjo bodies*

Order Instructions Type	Order No.	G	G ₁	SW	l	l ₁	L
HI-218Msv	KW 0311	G1/8	G1/8	14	6	7	53
HI-214Msv	KW 0312	G1/4	G1/4	17	8	8	61
HI-238Msv	KW 0313	G3/8	G3/8	20	9	10	71
HI-212Msv	KW 0314	G1/2	G1/2	27	10	11	82

* for banjo bodies see pages 92, 93

Delivery includes: 2 banjo bodies, 3 sealing rings

Fittings and accessories

Compression fittings

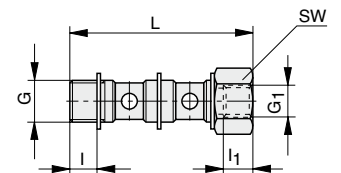

Compression nut for compression fittings

Order Instructions Type	Order No.	ØD	A	B	SW
UM-4Msv	KW 0710	4/2.7	M6x0.5	8.1	8
UM-5Msv	KW 0711	5/3	M7x0.75	8.5	8
UM-6/1Msv	KW 0712	6/4	M8x0.75	9.0	9
UM-6/2Msv	KW 0713	6/4	M10x1	10.5	12
UM-8Msv	KW 0714	8/6	M12x1	10.5	14
UM-10Msv	KW 0715	10/8	M14x1	11.5	16
UM-12Msv	KW 0716	12/10	M16x1	13.0	18
UM-15Msv	KW 0717	15/12.5	M20x1	15.5	22

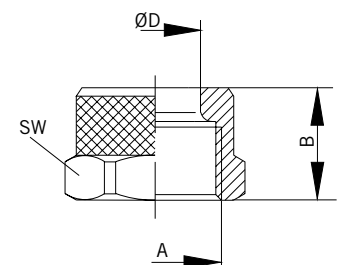

Dimensions in mm

Contents

Description	Page
Double nipple connectors	100, 101
Reducing nipple adaptors	101–103
Connectors	103, 104
Tee and Y adaptors, 4-way cross adaptors	104–106
Manifolds	107
Adaptor blocks	107, 108
Screw plugs	108, 109
Sealing rings, sealing tape	109, 110

Fittings for general installation work

*(rigid connections,
junctions, couplings,
etc.)*

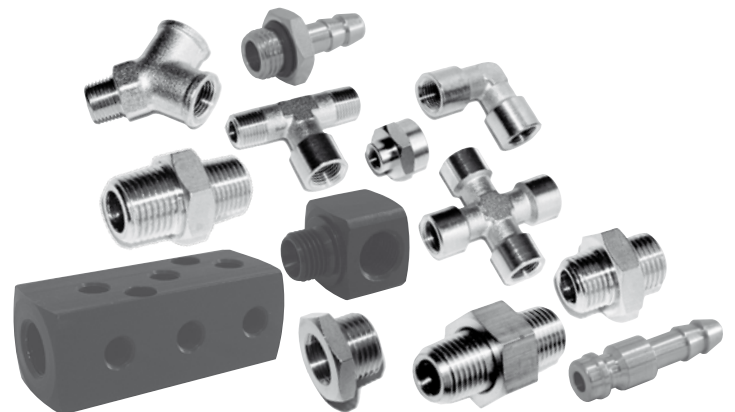

Fittings and accessories

Standard fittings

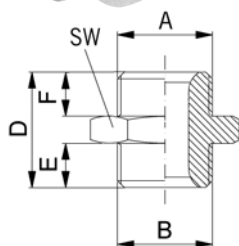

Double nipple connector, male parallel thread

Order Instructions		A	B	D	E	F	SW
Type	Order No.						
DZ-5050Msv	KW 0895	M5	M5	11.5	4	4	8
DZ-1818Msv	KW 0373	G1/8	G1/8	16.5	6	6	14
DZ-1414Msv	KW 0374	G1/4	G1/4	21.0	8	8	17
DZ-3838Msv	KW 0375	G3/8	G3/8	23.5	9	9	19
DZ-1212Msv	KW 0376	G1/2	G1/2	25.5	10	10	24
DZ-3434Msv	KW 0377	G3/4	G3/4	31.0	12	12	32
DZ-1010Msv	KW 0896	G1	G1	38.0	15	15	41

Reducing nipple adaptor, male parallel thread

Order Instructions		A	B	D	E	F	SW
Type	Order No.						
DZ-1805Msv	KW 0897	M5	G1/8	14.5	6	4	14
DZ-1814Msv	KW 0378	G1/8	G1/4	19.0	8	6	17
DZ-1838Msv	KW 0379	G1/8	G3/8	20.0	9	6	19
DZ-1438Msv	KW 0380	G1/4	G3/8	22.0	9	8	19
DZ-1412Msv	KW 0381	G1/4	G1/2	23.5	10	8	24
DZ-3812Msv	KW 0382	G3/8	G1/2	24.5	10	9	24
DZ-1234Msv	KW 0383	G1/2	G3/4	31.0	12	12	32
DZ-3410Msv	KW 0898	G3/4	G1	35.0	12	15	41

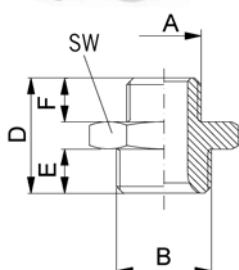

Double nipple connector, male taper thread (3 separable parts)

Order Instructions		A tap.	B	SW1	SW2 internal
Type	Order No.				
DT-1818	KY 6364	R1/8	27	15	5
DT-1414	KY 6365	R1/4	34	19	6
DT-3838	KY 6366	R3/8	36	22	8
DT-1212	KY 6367	R1/2	44	27	12
DT-3434	KY 6368	R3/4	52	36	14
DT-1010	KY 6369	R1	65	46	19

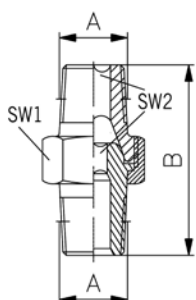
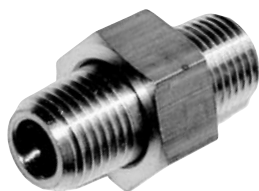

Dimensions in mm

Double nipple connector, male taper thread

Order Instructions		A tap.	B tap.	D	E	F	SW
Type	Order No.						
DK-1818Msv	KW 0368	R1/8	R1/8	20.5	8.0	8.0	12
DK-1414Msv	KW 0369	R1/4	R1/4	27.0	11.0	11.0	14
DK-3838Msv	KW 0370	R3/8	R3/8	28.0	11.5	11.5	17
DK-1212Msv	KW 0371	R1/2	R1/2	33.5	14.0	14.0	22
DK-3434Msv	KW 0372	R3/4	R3/4	39.5	16.5	16.5	27
DK-1010Msv	KW 0894	R1	R1	45.5	19.0	19.0	34

Reducing nipple adaptor, male taper thread

Order Instructions		A tap.	B tap.	D	E	F	SW
Type	Order No.						
DK-1814Msv	KW 0362	R1/8	R1/4	24.0	11.0	8.0	14
DK-1838Msv	KW 0363	R1/8	R3/8	24.5	11.5	8.0	17
DK-1438Msv	KW 0364	R1/4	R3/8	27.5	11.5	11.0	17
DK-1412Msv	KW 0365	R1/4	R1/2	30.5	14.0	11.0	22
DK-3812Msv	KW 0366	R3/8	R1/2	31.0	14.0	11.5	22
DK-1234Msv	KW 0367	R1/2	R3/4	37.0	16.5	14.0	27
DK-1034Msv	KW 0893	R3/4	R1	43.0	19.0	16.5	34

Reducing nipple adaptor, male / female parallel thread

Order Instructions		A	B	C	D	SW
Type	Order No.					
RNZ-185Msv	KW 0899	G1/8	M5	6	10.5	14
RNZ-1418Msv	KW 0411	G1/4	G1/8	8	13.0	17
RNZ-3818Msv	KW 0412	G3/8	G1/8	9	14.0	19
RNZ-3814Msv	KW 0413	G3/8	G1/4	9	14.0	19
RNZ-1214Msv	KW 0414	G1/2	G1/4	10	15.5	24
RNZ-1238Msv	KW 0415	G1/2	G3/8	10	15.5	24
RNZ-3412Msv	KW 0753	G3/4	G1/2	12	17.5	30
RNZ-1034Msv	KW 0900	G1	G3/4	15	23.0	41

Dimensions in mm

Fittings and accessories

Standard fittings

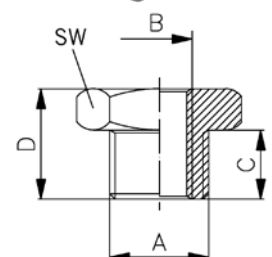
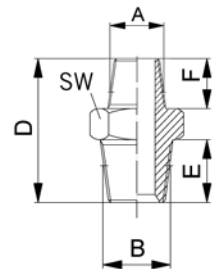
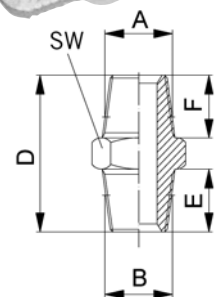

Fittings and accessories

Standard fittings

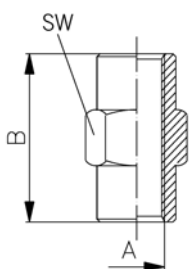
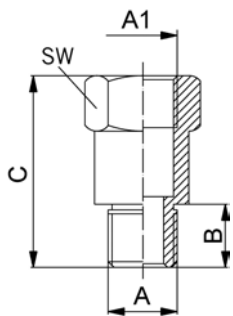
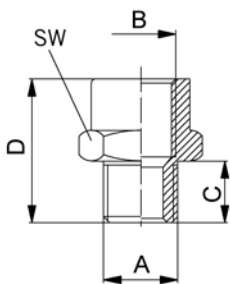

Reducing sleeve adaptor, male / female parallel thread

Order Instructions Type	Order No.	A	B	C	D	SW
RMZ-1805Msv	KW 0391	M5	G1/8	4	14.0	14
RMZ-1818Msv	KW 0392	G1/8	G1/8	6	16.0	14
RMZ-1814Msv	KW 0393	G1/8	G1/4	6	20.0	17
RMZ-1414Msv	KW 0394	G1/4	G1/4	8	22.0	17
RMZ-1438Msv	KW 0395	G1/4	G3/8	8	22.5	22
RMZ-3838Msv	KW 0396	G3/8	G3/8	9	23.5	22
RMZ-3812Msv	KW 0397	G3/8	G1/2	9	27.0	26
RMZ-1212Msv	KW 0398	G1/2	G1/2	10	28.0	26

Extended sleeve adaptor, male / female parallel thread

Order Instructions Type	Order No.	A	A1	B	C	SW
RMZL1-18Msv	KW 0399	G1/8	G1/8	6	22	14
RMZL2-18Msv	KW 0400	G1/8	G1/8	6	42	14
RMZL1-14Msv	KW 0401	G1/4	G1/4	8	35	17
RMZL2-14Msv	KW 0402	G1/4	G1/4	8	51	17

Sleeve connector, female parallel thread

Order Instructions Type	Order No.	A	B	SW
MU-50Msv	KW 0984	M5	11	8
MU-18Msv	KW 0416	G1/8	15	14
MU-14Msv	KW 0417	G1/4	22	17
MU-38Msv	KW 0418	G3/8	23	22
MU-12Msv	KW 0419	G1/2	28	26

Dimensions in mm

Reducing sleeve adaptor, female parallel thread

Order Instructions	A	B	C	SW	
Type	Order No.				
RMZJ-1814Msv	KW 0420	G1/8	G1/4	19.0	17
RMZJ-1838Msv	KW 0421	G1/8	G3/8	20.0	22
RMZJ-1438Msv	KW 0422	G1/4	G3/8	22.5	22
RMZJ-1412Msv	KW 0423	G1/4	G1/2	25.5	24
RMZJ-3812Msv	KW 0424	G3/8	G1/2	26.0	24

Fittings and accessories

Standard fittings

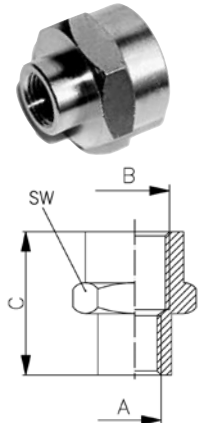

Equal elbow connector, male taper thread

Order Instructions	A1 tap.	A2 tap.	B	C	D	SW	
Type	Order No.						
WEA-18Msv	KW 0471	R1/8	R1/8	8.0	18.5	18.5	10
WEA-14Msv	KW 0472	R1/4	R1/4	11.0	23.5	23.5	13
WEA-38Msv	KW 0473	R3/8	R3/8	11.5	26.0	26.0	17
WEA-12Msv	KW 0752	R1/2	R1/2	14.0	31.0	31.0	21

Version R3/4 and R1 on request

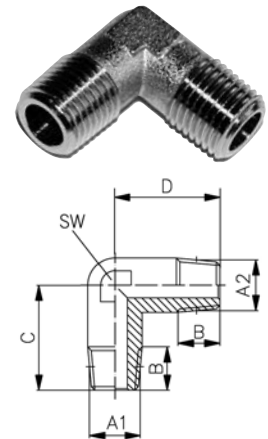

Elbow adaptor, male taper / female parallel thread

Order Instructions	A1 tap.	A2	B1	B2	C	D	SW	
Type	Order No.							
WEI-18Msv	KW 0467	R1/8	G1/8	8.0	8.0	18.5	21.0	10
WEI-14Msv	KW 0468	R1/4	G1/4	11.0	11.0	23.5	25.5	13
WEI-38Msv	KW 0469	R3/8	G3/8	11.5	11.5	26.0	28.0	17
WEI-12Msv	KW 0470	R1/2	G1/2	14.0	14.0	31.0	33.5	21

Version R3/4 and R1 on request

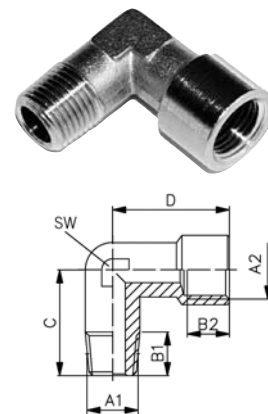

Dimensions in mm

Fittings and accessories

Standard fittings

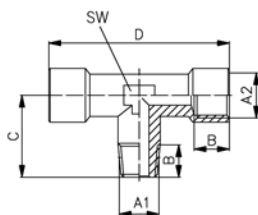
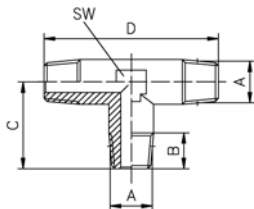
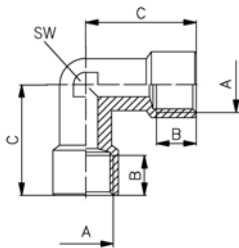

Equal elbow connector, female parallel thread

Order Instructions		A	B	C	SW
Type	Order No.				
WII-18Msv	KW 0460	G1/8	8.0	21.0	10
WII-14Msv	KW 0461	G1/4	11.0	25.5	13
WII-38Msv	KW 0462	G3/8	11.5	28.0	17
WII-12Msv	KW 0463	G1/2	14.0	33.5	21

Taper thread version R3/4 and R1 on request

Equal tee connector, male taper thread

Order Instructions		A tap.	B	C	D	SW
Type	Order No.					
TEC-18Msv	KW 0490	R1/8	8.0	21.0	37	10
TEC-14Msv	KW 0491	R1/4	11.0	25.5	47	13
TEC-38Msv	KW 0492	R3/8	11.5	28.0	52	17
TEC-12Msv	KW 0493	R1/2	14.0	33.5	62	21

Version R3/4 and R1 on request

Branch tee adaptor, male taper / female parallel thread

Order Instructions		A1 tap.	A2	B	C	D	SW
Type	Order No.						
TEA-18Msv	KW 0482	R1/8	G1/8	8.0	18.5	42	10
TEA-14Msv	KW 0483	R1/4	G1/4	11.0	23.5	51	13
TEA-38Msv	KW 0484	R3/8	G3/8	11.5	26.0	56	17
TEA-12Msv	KW 0485	R1/2	G1/2	14.0	31.0	67	21

Taper thread version R3/4 and R1 on request

Dimensions in mm

Branch tee adaptor, male taper / female parallel thread

Order Instructions		A1 tap.	A2	B	C	D	SW
Type	Order No.						
TEB-18Msv	KW 0486	R1/8	G1/8	8.0	21.0	37	10
TEB-14Msv	KW 0487	R1/4	G1/4	11.0	25.5	47	13
TEB-38Msv	KW 0488	R3/8	G3/8	11.5	28.0	52	17
TEB-12Msv	KW 0489	R1/2	G1/2	14.0	33.5	62	21

Taper thread version R3/4 and R1 on request

Equal tee connector, female parallel thread

Order Instructions		A	B	C	D	SW
Type	Order No.					
TI-18Msv	KW 0478	G1/8	8.0	21.0	42	10
TI-14Msv	KW 0479	G1/4	11.0	25.5	51	13
TI-38Msv	KW 0480	G3/8	11.5	28.0	56	17
TI-12Msv	KW 0481	G1/2	14.0	33.5	67	21
TI-34Msv	KW 0773	G3/4	16.5	36.5	73	25

Version G1 on request

Y adaptor, male / female parallel thread

Order Instructions		A1 tap.	A2	B	SW
Type	Order No.				
YAI-18Msv	KW 0505	R1/8	G1/8	8.0	14
YAI-14Msv	KW 0506	R1/4	G1/4	11.0	17
YAI-38Msv	KW 0507	R3/8	G3/8	11.5	22
YAI-12Msv	KW 0991	R1/2	G1/2	14.0	26

Dimensions in mm

Fittings and accessories

Standard fittings

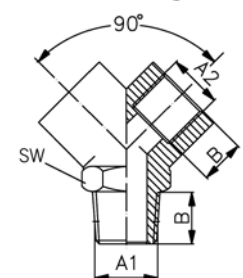
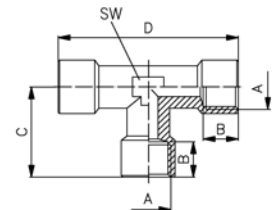
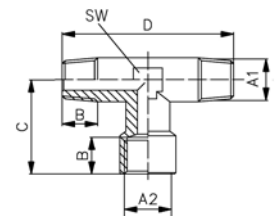

Fittings and accessories

Standard fittings

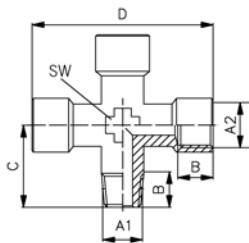

4-way cross adaptor, male taper / female parallel thread

Order Instructions	Order No.	A1 keg.	A2	B	C	D	SW
TEF-18Msv	KW 0502	R1/8	G1/8	8.0	18.5	42	10
TEF-14Msv	KW 0503	R1/4	G1/4	11.0	23.5	49	13
TEF-38Msv	KW 0504	R3/8	G3/8	11.5	26.0	54	17
TEF-12Msv	KW 0988	R1/2	G1/2	14.0	31.0	67	21

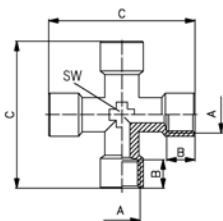

4-way cross connector, female parallel thread

Order Instructions	Order No.	A	B	C	SW
KEI-18Msv	KW 0464	G1/8	8.0	42	10
KEI-14Msv	KW 0465	G1/4	11.0	51	13
KEI-38Msv	KW 0466	G3/8	11.5	56	17
KEI-12Msv	KW 0987	G1/2	14.0	67	21

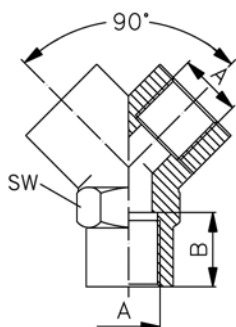

Equal Y connector, female parallel thread

Order Instructions	Order No.	A	B	SW
YI-18Msv	KW 0509	G1/8	8.0	14
YI-14Msv	KW 0510	G1/4	11.0	17

Dimensions in mm

4-way manifold

Order Instructions		A	B	C	∅	SW
Type	Order No.					
VB-18ALN	KW 0474	G1/8	4	25	4.5	15
VB-14ALN	KW 0475	G1/4	7	40	5.5	20
VB-38ALN	KW 0476	G3/8	8	50	5.5	25
VB-12ALN	KW 0477	G1/2	8	50	5.5	33

9-way manifold

Order Instructions		G	G ₁ (9x)	A	B	D	L	L ₁	L ₂	L ₃	L ₄	L ₅
Type	Order No.											
VL-185ALS	KY 6540	G1/8	M5	20	12.0	4.5	50	15	15	12	18	18
VL-3818ALS	KY 6541	G3/8	G1/8	30	19.5	5.5	80	24	24	20	30	28
VL-1214ALS	KY 6542	G1/2	G1/4	36	24.0	6.5	100	30	30	23	36	34

Material: aluminium, black-anodized

Elbow adaptor block, male / female parallel thread

Order Instructions		G	A	I	L	L ₁
Type	Order No.					
WE-05	KY 6370	M5	10	4.5	14.0	5,3
WE-18	KY 6371	G1/8	15	6.5	23.0	9.0
WE-14	KY 6372	G1/4	22	9.0	29.0	11.0
WE-38	KY 6373	G3/8	27	9.0	32.0	12.5
WE-12	KY 6374	G1/2	36	11.0	40.5	15.8

Material: aluminium, black-anodized

Dimensions in mm

Fittings and accessories

Standard fittings

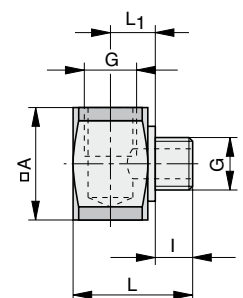
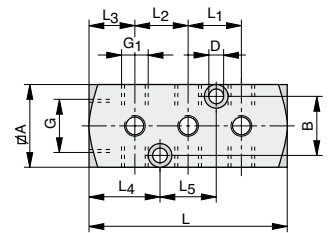
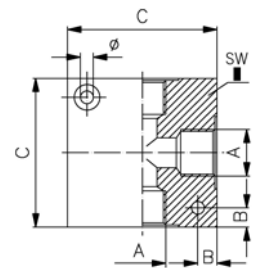

Fittings and accessories

Standard fittings

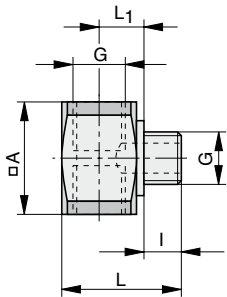

Tee adaptor block, male / female parallel thread

Order Instructions	Order No.	G	A	I	L	L ₁
TE-05	KY 6375	M5	10	4.5	14.0	5.3
TE-18	KY 6376	G1/8	15	6.5	23.0	9.0
TE-14	KY 6377	G1/4	22	9.0	29.0	11.0
TE-38	KY 6378	G3/8	27	9.0	32.0	12.5
TE-12	KY 6379	G1/2	36	11.0	40.5	15.8

Material: aluminium, black-anodized

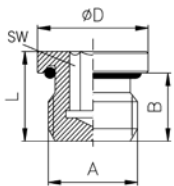

Screw plug, male parallel thread, hexagon socket and O-ring

Order Instructions	Order No.	A	B	L	ØD	SW
VS-5Msv	KW 0425	M5	4.6	7.5	8	2.5
VS-18Msv	KW 0426	G1/8	6.5	9.5	14	5.0
VS-14Msv	KW 0427	G1/4	8.0	11.5	17	6.0
VS-38Msv	KW 0428	G3/8	9.0	12.5	20	8.0
VS-12Msv	KW 0429	G1/2	11.0	14.0	26	10.0

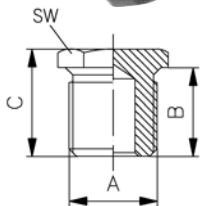

Screw plug, male parallel thread

Order Instructions	Order No.	A	B	C	SW
VS-5Msv	KW 0985	M5	4.0	7.5	8
VS-18Msv	KW 0430	G1/8	6.5	10.5	14
VS-14Msv	KW 0431	G1/4	8.0	13.0	17
VS-38Msv	KW 0432	G3/8	9.0	14.0	19
VS-12Msv	KW 0433	G1/2	10.0	15.5	24
VS-34Msv	KW 0434	G3/4	11.0	15.5	30
VS-10Msv	KW 0986	G1	12.0	17.0	40

Dimensions in mm

Cap nut, female parallel thread

Order Instructions		A	B	C	SW
Type	Order No.				
VM-18Msv	KW 0435	G1/8	8.0	12.0	14
VM-14Msv	KW 0436	G1/4	11.0	15.5	17
VM-38Msv	KW 0437	G3/8	11.5	17.0	20
VM-12Msv	KW 0438	G1/2	14.0	21.0	24

Fittings and accessories

Standard fittings
Sealing rings

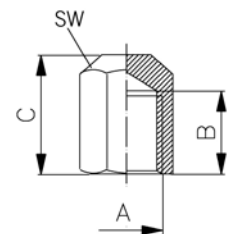

Sealing rings

Order Instructions		For port size	$\varnothing D_1$	$\varnothing D_2$	s	Material
Type	Order No.					
Aluminium Sealing Rings						
DI-18AL	KW 0349	G1/8	10.2	13.8	1.5	Aluminium
DI-14AL	KW 0350	G1/4	13.3	17.7	1.5	Aluminium
DI-38AL	KW 0351	G3/8	16.9	21.0	1.5	Aluminium
DI-12AL	KW 0352	G1/2	21.1	26.0	1.5	Aluminium
DI-34AL	KZ 7865	G3/4	26.5	31.0	2.0	Aluminium
DI-10AL	KZ 7866	G1	33.5	39.0	1.0	Aluminium
Plastic Sealing Rings						
DI-5KU	KW 0582	M5	5.3	7.7	1.0	PVC-hard
DI-18KU	KW 0354	G1/8	10.2	13	1.5	PVC-hard
DI-14KU	KW 0355	G1/4	13.4	17.9	2.0	PVC-hard
DI-38KU	KW 0356	G3/8	17.1	21.8	2.0	PVC-hard
DI-12KU	KW 0357	G1/2	21.3	26.5	2.0	PVC-hard
Copper Sealing Rings						
DI-5CU	KW 0583	M5	5.0	7.5	1.0	Copper
DI-18CU	KW 0584	G1/8	10.0	14.0	1.5	Copper
DI-14CU	KW 0585	G1/4	13.5	18.0	1.5	Copper
DI-38CU	KW 0586	G3/8	17.0	21.0	1.5	Copper
DI-12CU	KW 0587	G1/2	21.0	26.0	1.5	Copper

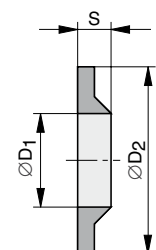
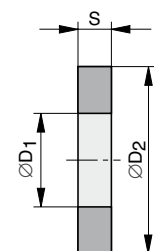

Pressure gauge sealing ring

Order Instructions		für A-Gr.	$\varnothing D_1$	$\varnothing D_2$	s	Material
Type	Order No.					
MD-18	KZ 7430	G1/8	9.4	15	4.2	Plastic
MD-14	KZ 7431	G1/4	12.8	18.6	4.5	Plastic

Dimensions in mm

Fittings and accessories

Sealing tape



Thread sealing tape

Order Instructions Type	Order No.	Thickness	Length
GD-128	KY 9426	0.08 mm	12 m

Dimensions in mm

Contents

Description	Page
Characteristics	112
Tube/hose adaptors	113
Tube/hose stem adaptors	113
Tubings	114–116
Tube holders, bundling spirals	116, 117
Hose/O-clips	117
Tube cutter	117

Tube / hose fittings

Fittings for tubing and hosing in special applications

- Tube/hose adaptors
- Tubings
- Tube accessories



Tube / hose fittings

Fittings for tubing and hosing in special applications

Sealing: by hose clip

- Metal types: nickel-plated brass with male parallel thread and integrated O-ring for thread sealing
- Plastic types in combination with plastic push-in fittings (see section on push-in fittings)
- Metal types (nickel-plated brass) in combination with quick-release couplings (see section on miscellaneous accessories)

Characteristics

Characteristics	Symbol	Unit	Description
Connecting thread			G1/8, G1/4, G3/8, G1/2, G3/4 (parallel)
Tubing/ hose outside diameter		mm	Ø4, Ø6, Ø8, Ø9, Ø11, Ø13, Ø19
Material			
– Body			Nickel-plated brass
– O-ring			NBR
Operating pressure range	$p_{\min/\max}$	bar	0 to 18
Medium			Compressed air (other media on request)

Tubing / Hose Recommendations¹⁾

Tubing / hose type	Depending on application
Tubing / hose material	PVC (polyester-braided or glassfibre-reinforced) PU

¹⁾ see section on tubing and hoses, pages 114, 115



Dimensions in mm

Tube / hose adaptor, male parallel thread with O-ring

Order Instructions Type	Order No.	Tube/Hose Ø ID	Port size G	L	L ₁	SW
STO-184Msv	KW 0974	4	G1/8	31	6	15
STO-186Msv	KW 0439	6	G1/8	31	6	15
STO-146Msv	KW 0440	6	G1/4	33	8	18
STO-188Msv	KW 0442	8	G1/8	31	6	15
STO-148Msv	KW 0443	8	G1/4	33	8	18
STO-388Msv	KW 0444	8	G3/8	34	9	21
STO-149Msv	KW 0975	9	G1/4	33	8	18
STO-389Msv	KW 0976	9	G3/8	34	9	21
STO-1211Msv	KW 0447 ¹⁾	11	G1/2	36	11	26
STO-3813Msv	KW 0977	13	G3/8	39	9	21
STO-1213Msv	KW 0978	13	G1/2	41	11	26
STO-3413Msv	KW 0979	13	G3/4	45	14	32
STO-3419Msv	KW 0980	19	G3/4	48	14	32

Material: nickel-plated brass

¹⁾ type to be discontinued

Tube / hose fittings

Tube / hose adaptors

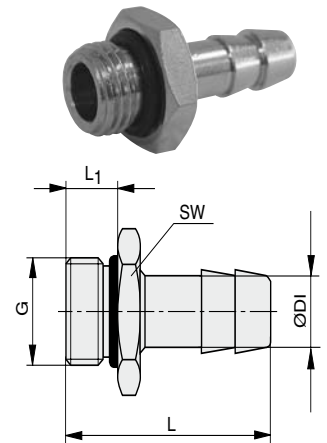

Tube / hose stem adaptor*

Order Instructions Type	Order No.	NW	Tube/Hose ØOD/ID	Stem ØA	ØD	L	L ₁	L ₂
SST-84P	KX 5326	2.8	6/4	6	13.0	41.8	18.0	20.8
SST-86P	KX 5327	3.5	8/6	8	14.8	43.1	19.3	20.8
SST-108P	KX 5328	6.7	10/8	10	17.8	46.1	22.2	20.8

Material: Plastic

* see also page 121, 122

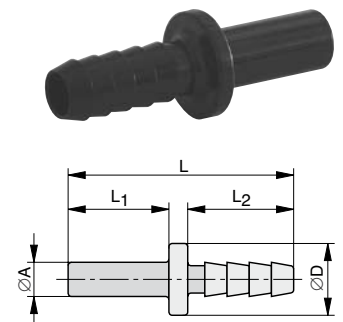

Quick release coupling plug, hose barb*

Order Instructions Type	Order No.	NW	Tube/Hose Ø ID	L	L ₁	L ₂
ST-32	KX 5657	2.7	3	24	10.0	13
ST-42	KX 5658	2.7	4	24	10.0	13
ST-45	KY 6452	5.0	4	32	14.0	17
ST-65	KY 6453	5.0	6	32	14.0	17
ST-47	KY 6454	7.8	4	48	20.0	25
ST-67	KX 5053	7.8	6	48	20.0	25
ST-97	KY 6455	7.8	9	48	20.0	25
ST-137	KY 6456	7.8	13	48	20.0	25
ST-1310	KY 6197	10.0	13	48	21.5	25

Material: nickel-plated brass (ST-1310: nickel-plated steel)

* see also page 121, 122

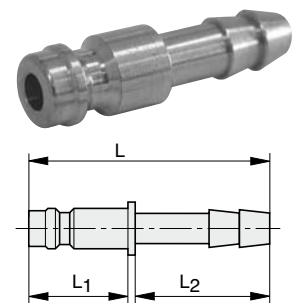

Dimensions in mm

Quality tubing

for a wide range
of applications

Tube accessories
(hose clips, tube holder
racks, tube cutters...
– see pages 116, 117)

Characteristics

Characteristics	Symbol	Unit	Description
Material			Polyethylene, polyurethane, nylon, PVC (polyester-braided), PVC (glassfibre-reinforced), rubber (metal-braided)
Operating pressure range	$p_{\min/\max}$	bar	See specific data
Temperature range			See specific data
Bending radii			See specific data

Tubing recommendations¹⁾

Description	Characteristics and resistance*
Polyethylene tubing (Parker Origa Type PE-):	Low cost tubing for general use (not suitable for push-in fittings), lightweight, impact resistant and generally resistant to acids, alkalis and salt solutions. Tubing runs should be straight (danger of cracking).
Polyurethane tubing (Parker Origa Type PU-):	Good recovery properties (low deformation), high tear resistance, very good cold flexibility, resistant to most lubricating oils, resistant to ageing with oxygen and ozone, especially flexible.
Nylon (Parker Origa Type PS-):	Flexible tubing (calibrated) for use with push-in fittings, high impact and notched bar impact resistance, lightweight and easy to install, resistant to hydraulic oils and fuels.
PVC tubing (Parker Origa Type DH- , polyester-braided):	Flexible, resistant to weathering and ageing, generally resistant to diluted acids, alkalis, greases and various oils, resistant to abrasion.
PVC tubing (Parker Origa Type DVOH- , glassfibre-reinforced):	Especially flexible, lightweight tubing with high pressure resistance, generally resistant to diluted acids, alkalis, greases and various oils, especially suitable for pneumatic-hydraulic systems.
Rubber tubing (Parker Origa Type PBM-., metal-braided):	Oil-resistant rubber tubing with metal braiding for protection (e.g. for welding systems).

* These are general notes: for special applications, the suitability of the tubing should always be carefully checked.

Polyethylene tubing

Order Instructions				Tube ØOD/ID	Permissible Pressure(bar)		Min. bending radius (mm)	Length/ roll
Type	Order No. / Colours				20°C	50°C (t_{\max})		
	Transparent	Blue	Black					
PE-42	M857-5149	M857-5443	M857-5381	4/2	20	12	20	50 m
PE-53	M857-5299	M857-5059	M857-5152	5/3	15	9	25	50 m
PE-64	M857-5183	M857-5064	M857-5066	6/4	13	8	30	50 m
PE-86	M857-5184	M857-5070	M857-5298	8/6	8	5	40	50 m
PE-108	M857-5185	M857-5073	M857-5365	10/8	6	4	60	50 m

Size ØOD/ID 12/10 available on request

Polyurethane tubing

Order Instructions				Tube ØOD/ID	Permissible pressure (bar)		Min. bending radius (mm)	Length/ roll
Type	Order No. / Colours				20°C	50°C (t _{max})		
	Transparent	Blue	Black					
PU-42	KW 0995	KW 0996	KW 0997	4/2	8	5.5	13	50 m
PU-53	M814-5255	M814-5059	M814-5152	5/3	8	5.5	14	50 m
PU-64	M814-5062	M814-5064	M814-5066	6/4	8	5.5	20	50 m
PU-86	M814-5175	M814-5070	M814-5298	8/6	8	5.5	36	50 m
PU-108	M814-5173	M814-5073	M814-5368	10/8	8	5.5	48	50 m

Quality tubing

for a wide range
of applications

Tube accessories
(hose clips, tube holder
racks, tube cutters...
– see pages 116, 117)

Nylon tubing for push-in fittings

Order Instructions				Tube ØOD/ID	Permissible pressure (bar)		Min. bending radius (mm)	Length/ roll
Type	Order No. / Colours				20°C	50°C (t _{max})		
	Transparent	Blue	Black					
PS-427	M812-5322	M812-5454	M812-5408	4.0/2.7	45	9.0	30	50 m
PS-53	M812-5366	M812-5455	M812-5457	5.0/3.0	34	7.0	25	50 m
PS-64	M812-5323	M812-5386	M812-5458	6.0/4.0	27	5.5	30	50 m
PS-86	M812-5324	M812-5389	M812-5459	8.0/6.0	19	4.0	40	50 m
PS-108	M812-5332	M812-5412	M812-5460	10.0/8.0	15	3.0	60	50 m
PS-1210	M812-5333	M812-5456	M812-5461	12.0/10.0	12	2.5	85	50 m
PS-1411	KW 0906	KW 0907	KW 0908	14.0/11.0	16	3.2	80	50 m

* at +50°C the permissible pressure is 3 times the value at +90°C

Polyester-braided PVC tubing

Order Instructions		Tube ØOD/ID	Permissible pressure (bar)		Min. bending radius (mm)	Length/ roll
Type	Order No. / Colour		20°C	60°C (t _{max})		
	Transparent					
DH-126N	M870-5307	12/6	18	10	ca. 10 x tube inside diameter	50 m
DH-148N	M870-5304	14/8	16	8		50 m
DH-159N	M870-5305	15/9	14	7		50 m
DH-1610N ¹⁾	M870-5261 ¹⁾	16/10	12	6		50 m
DH-1912N	M870-5306	19/12	12	6		50 m
DH-2013N	M870-5262	20/13	12	6		50 m
DH-2719N	KW 0962	27/19	10	5		50 m

¹⁾ type to be discontinued

Glassfibre-reinforced PVC tubing

Order Instructions		Tube ØOD/ID	Permissible pressure (bar)		Min. ben- ding radius (mm)	Length/ roll
Type	Order No. / Colour		20°C	60°C (t _{max})		
	Blue					
DVOH-64B	M870-5303	6.2/4.0	40	28	50	50 m
DVOH-86B	M870-5302	8.2/6.0	40	28	60	50 m
DVOH-108B	M870-5300	10.2/8.0	35	24	65	50 m
DVOH-1512B	M870-5301	15.0/12.5	28	20	80	50 m

Quality tubing

for a wide range
of applications

– Tube accessories

Metal-braided rubber tubing

Order Instructions		Tube ØOD/ID	Permissible pressure (bar) 20°C	Min. bending radius (mm)	Length/ Roll
Type	Order No. / Colour				
	Silver				
PBM-96S	M850-5437	9/6	12	30	50 m
PBM-129S	M850-5438	12/9	12	45	50 m

Nylon spiral tubing (with or without connectors G1/8, G1/4)

Order Instructions		Version	Colour	Tube ØOD/ID	Permissible pressure (bar) 20°C	Working length	Spiral Ø Inside
Type	Order No.						
PAS-64N	KW 0719	without connectors	Transpa- rent	6/4	12	5 m	60
PAS-86N	KW 0720	without connectors	Transpa- rent	8/6	12	5 m	60
PAS-64B	KY 0050	with connectors G1/8	Blue	6/4	12	5 m	60
PAS-86B	KY 0048	with connectors G1/4	Blue	8/6	12	5 m	60
PAS-108B	KY 0051	with connectors G1/4	Blue	10/8	12	5 m	60

Tubing accessories

– Tube holders

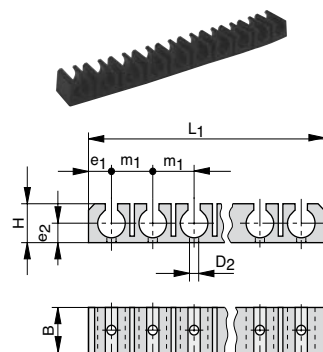

Tube holder rack (10-fold)

Order Instructions		Tube ØOD	B	H	L ₁	D ₂	e ₁	e ₂	m ₁
Type	Order No.								
KL-53*	KX 5614	5	13.5	9	96.0	2.5	4.3	6.0	9.7
KL-64	KX 5615	6	13.5	9	105.0	3.0	5.2	5.5	10.5
KL-86	KX 5616	8	15.5	12	135.0	3.0	6.8	7.5	13.5
KL-108	KZ 4953	10	18.0	15	119.2	2.8	8.6	10.0	20.4

* also for tube ØOD = 4
Material: Nylon PA 6

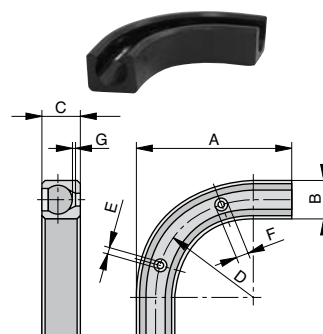

Elbow tube holder

Order Instructions		Tube ØOD	A	B	C	D	E	F	G
Type	Order No.								
HB-8P	KX 5329	8	37	13	10	22	3.2	6.6	1.7
HB-10P	KX 5330	10	47	15	12	30	3.2	6.6	1.7

Material: POM

Dimensions in mm

Tube bundling spiral

Order Instructions	Order No.	Number of tubes	Tube ØOD/ID
Type			
SBS	KX5613	20	5/3
		15	6/4
		8	8/6
		5	10/8

Werkstoff: Polyethylen

Tubing accessories

- Tube bundling spiral
- Hose clip
- Tube cutter

Hose clip

Type	Order No.	Tubing range
SCH-812	KX 5622	8-12 mm
SCH-1016	KX 5623	10-16 mm
SCH-1220	KX 5624	12-20 mm
SCH-1625	KX 5399	16-25 mm
SCH-2032	KW 0934	20-32 mm
SCH-2540	KY 6901	25-40 mm

Material: zinc-plated steel



O-clip

Type	Order No.	Tubing range
SCHK-911	KX 5617	9-11 mm
SCHK-1113	KX 5618	11-13 mm
SCHK-1315	KX 5619	13-15 mm
SCHK-1417	KX 5620	14-17 mm
SCHK-1820	KX 5621	18-20 mm

Material: zinc-plated steel



Tube cutter

Type	Order No.
PSA-1	KY 6813

Material: plastic/steel



Dimensions in mm

Contents

Description	Page
Characteristics	120
Quick release couplings bodies	121
Quick release coupling plugs	121, 122
Quick release coupling plugs, hose barb	122
3/2-way slide valves	123
Manifolds with integrated ball valves	124
Ball valves	125, 126
Spray guns	127

Air line accessories

- *Quick release couplings, self-sealing*
- *3/2 way slide valves*
- *Manifolds with integrated ball valves*
- *Ball valves*
- *Blow guns*



Air line accessories

- Quick release couplings, self-sealing
- 3/2 way slide valves
- Manifolds with integrated ball valves
- Ball valves
- Blowguns

Characteristics

Characteristics	Symbol	Unit	Description
General Features			
Nominal bore	NW	mm	2.7 5,0 7.2
Operating pressure range	$p_{\min/\max}$	bar	0 to 35
Temperature range	$T_{\min/\max}$	°C	-20 to +100
Medium			Compressed air (other media on request)
3/2 way slide valves*			
Material			Body: nickel-plated brass Sleeve: aluminium, black anodized
Port size			M5, G1/8, G1/4, G3/8, G1/2
Quick release couplings			
Material			Body: nickel-plated brass Sleeve: aluminium
Port size			M5, G1/8, G1/4, G3/8, G1/2
Ball valves, heavy wight type			
Material			Body: chrome-plated brass Ball: chrome-plated brass Handle: zinc-plated and lacquered steel Seals: PTFE
Port size			G1/4, G3/8, G1/2, G3/4, G1
Operating pressure range	$p_{\min/\max}$	bar	0 to 25 (50 depending on size)
Temperature range	$T_{\min/\max}$	°C	-20 to +150 (in absence of steam)
Medium			Compressed air (other media on request)
Mini ball valve			
Material			Body: chrome-plated brass Ball: brass Handle: PA66 Seals: PTFE O-ring: NBR70
Port size			G1/8, G1/4
Operating pressure range	$p_{\min/\max}$	bar	0 to 20
Temperature range	$T_{\min/\max}$	°C	-18 to +80
Medium			Compressed air (other media on request)
Blow guns			
Material			Aluminium
Port size			for tubes NW6, NW9



Dimensions in mm

Quick release coupling body, self-sealing, male parallel thread

Order Instructions		NW	A	B	ØD	L	SW
Type	Order No.						
KA-525	KX 5640	2.7	M5	5	10	26	9
KA-185	KY 1006	5.0	G1/8	7	16	36	14
KA-145	KY 1007	5.0	G1/4	9	16	38	17
KA-187	KY 1008	7.2	G1/8	9	27	43	22
KA-147	KY 1009	7.2	G1/4	9	27	43	22
KA-387	KY 1010	7.2	G3/8	9	27	43	22
KA-127	KY 1011	7.2	G1/2	12	27	46	22

Quick release coupling body, self-sealing, female parallel thread

Order Instructions		NW	A	B	ØD	L	SW
Type	Order No.						
KI-525	KX 5647	2.7	M5	5	10	26	9
KI-185	KY 1012	5.0	G1/8	7	16	36	14
KI-145	KY 1013	5.0	G1/4	9	16	38	17
KI-147	KY 1015	7.2	G1/4	9	27	43	22
KI-387	KY 1016	7.2	G3/8	9	27	43	22
KI-127	KY 1017	7.2	G1/2	12	27	46	24

Quick release coupling plug, compression fitting

Order Instructions		NW	A	L
Type	Order No.		for tube Ø	
SV-532	KX 5654	2.7	3x5	25
SV-642	KX 5655	2.7	4x6	25
SV-645	KY 6447	5.0	4x6	32
SV-865	KY 6448	5.0	6x8	32
SV-647	KY 6449	7.2	4x6	34
SV-867	KY 6450	7.2	6x8	34
SV-1087	KY 6451	7.2	8x10	42

Dimensions in mm

Air line accessories

– Quick release couplings, self-sealing

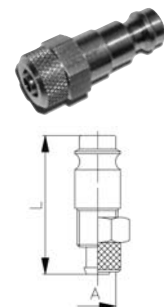
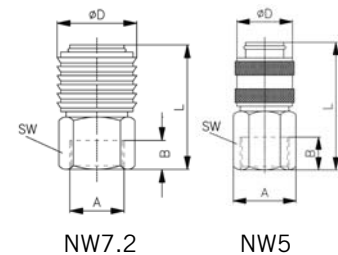
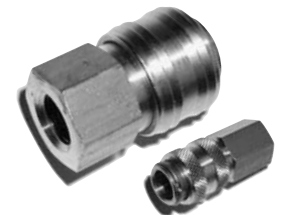
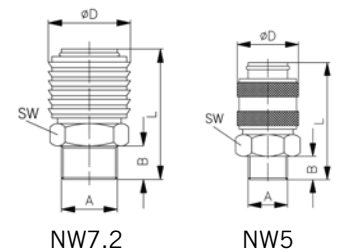

Air line accessories

– Quick release couplings, self-sealing

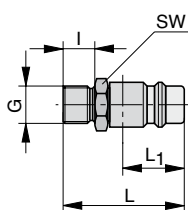

Quick release coupling plug, male parallel thread

Order Instructions		NW	G	I	L	L ₁	SW
Type	Order No.						
SA-525	KX 5659	2.7	M5	5.0	18	10.5	7
SA-185	KY 6457	5.0	G1/8	7.0	25	14.0	14
SA-145	KY 6458	5.0	G1/4	9.0	28	14.0	17
SA-187	KY 6459	7.8	G1/8	6.5	31	20.0	14
SA-147	KY 6460	7.8	G1/4	9.0	33	20.0	17
SA-387	KY 6461	7.8	G3/8	9.0	33	20.0	19
SA-127	KY 6462	7.8	G1/2	12.0	38	20.0	22
SA-340	KX6200	10,0	G3/4	19.0	46	21.0	27

Material: nickel-plated brass (SA-340 nickel-plated steel)

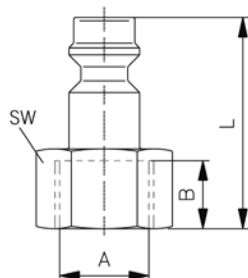

Quick release coupling plug, female parallel thread

Order Instructions		NW	A	B	L	SW
Type	Order No.					
SI-525	KX 5636	2.7	M5	5	17	7
SI-185	KY 6463	5.0	G1/8	8	25	14
SI-145	KY 6464	5.0	G1/4	9	26	17
SI-187	KY 6465	7.2	G1/8	7	30	14
SI-147	KY 6466	7.2	G1/4	10	33	17
SI-387	KY 6467	7.2	G3/8	10	33	19
SI-127	KY 6468	7.2	G1/2	12	36	24

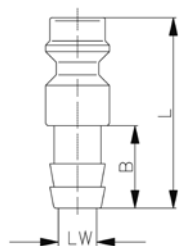

Quick release coupling plug, hose barb

Order Instructions		NW	LW for tube Ø	B	L
Type	Order No.				
ST-32	KX 5657	2.7	3	13.0	24
ST-42	KX 5658	2.7	4	13.0	27
ST-45	KY 6452	5.0	4	17.0	32
ST-65	KY 6453	5.0	6	16.5	32
ST-67	KX 5053	7.2	6	24.0	44
ST-97	KY 6455	7.2	9	23.0	44
ST-137	KY 6456	7.2	13	23.0	44

Material: nickel-plated brass

Dimensions in mm

3/2 way slide valves

Order Instructions		A	ØB	L	SW	Nominal flow Q _N (l/min)	
Type	Order No.					P → A	A → R
HS-05	KC4303	M5	15	33.5	10	170	350
HS-18	KC4304	G1/8	25	48.0	14	700	1280
HS-14	KC4305	G1/4	30	58.0	19	1500	2220
HS-38	KC4306	G3/8	35	68.0	22	2200	3200
HS-12	KC4307	G1/2	40	80.0	27	3400	7500

Air line accessories

– 3/2 way slide valves

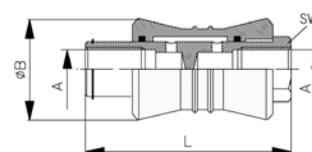

Dimensions in mm

Air line accessories

– Manifold with integrated ball valves

Series VL

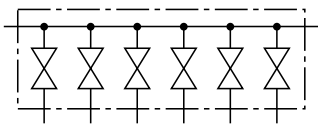

This manifold (with integrated ball valves) allows individual sections of a machine to be shut off.

The slot indicates the position of the ball valves.

Characteristics			Pressures quoted as gauge pressure
Characteristics	Symbol	Unit	Description
General features			
Series			Manifold with integrated ball valves
Type			VL-3/8
Port size			Input 2 x G3/8, Output 6 x G1/4
Nominal bore	NW(DN)	mm	8
Mounting			2 screws M5
Material			
– Housing			Anodized aluminium
– Ball/spindle			chrome-plated brass Ms 58
– Ball seal			Teflon (PTFE)
– O-rings			Buna N (NBR)
Temperature range		°C	-10 to +100
Operating pressure range	p_{max}	bar	10
Actuation			Screwdriver (size 4 – 6 mm)
Actuation angle			90°
Weight (mass)		kg	0.65

Dimensions

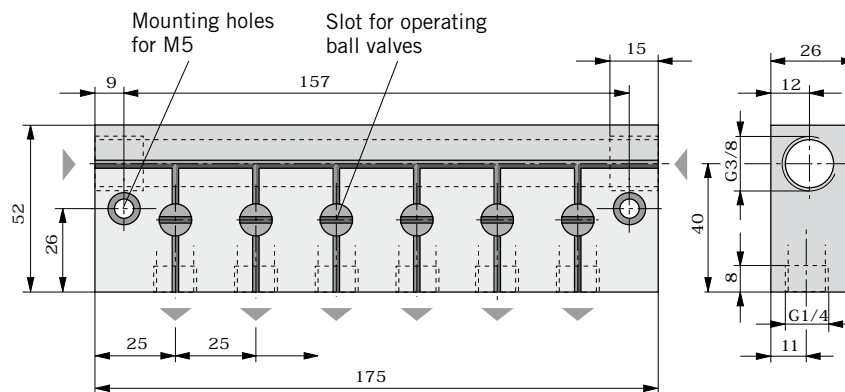

Order Instructions: Type VL3/8

Order No. KL4088

Dimensions in mm

Ball valves without venting

Order Instructions		A	NW	ØB	C	D	E	SW	p _{max} (bar)
Type	Order No.								
KH-14	KZ 4451	G1/4	10	25.5	51	80	40	18	50
KH-38	KZ 4452	G3/8	10	25.5	60	80	40	21	50
KH-12	KZ 4453	G1/2	15	32.5	75	89	50	25	50
KH-34	KZ 4454	G3/4	20	42.0	80	113	59	31	40
KH-10	KZ 4455	G1	25	49.5	90	113	63	38	40

Air line accessories

– Ball valves

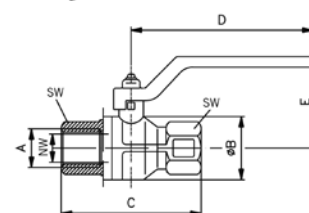
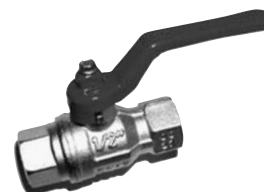

Ball valves with venting

Order Instructions		A	NW	ØB	C	D	E	SW	p _{max} (bar)
Type	Order No.								
KHE-14	KZ 4660	G1/4	8	10	45	96	47	20	12
KHE-38	KZ 4701	G3/8	10	10	45	96	47	20	12
KHE-12	KZ 4683	G1/2	15	14	59	96	52	25	12
KHE-34	KZ 4702	G3/4	20	15	64	116	59	31	12
KHE-10	KZ 4703	G1	25	20	81	116	63	40	12
KHE-14BE*	PG10025	G1/4	8	10	45	96	47	20	12
KHE-12BE*	KW 0643	G1/2	15	14	59	96	52	25	12

* Lockable version

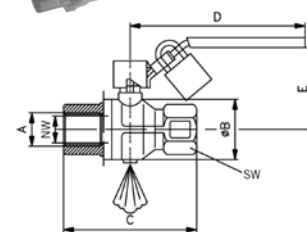

Dimensions in mm

Air line accessories

– Ball valves

Ball valves without venting

Order Instructions	A	A1	B	C	D	E	∅	SW1	SW2	p _{max} (bar)	
KHM-18AI	KW0709	R1/8	G1/8	8	35.5	19	21	5.5	14	14	20
KHM-14AI	KW0708	R1/4	G1/4	11	38.0	19	21	5.5	14	14	20

Other sizes on request

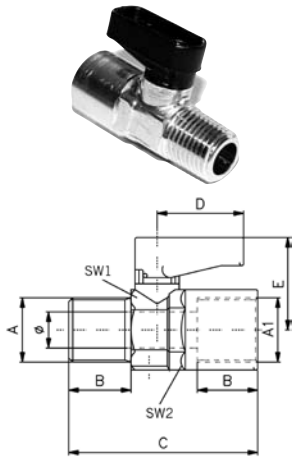

Ball valves without venting

Order Instructions	A	A1	B	C	D	E	∅	SW1	SW2	p _{max} (bar)	
KHM-18I	KW0707	G1/8	G1/8	8	36.5	19	21.5	5.5	14	14	20
KHM-14I	KW0702	G1/4	G1/4	11	43.0	19	21.5	5.5	14	14	20

Other sizes on request

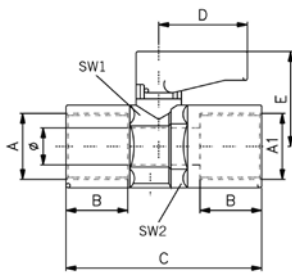

Dimensions in mm

Spray guns with nipples

Order Instructions	Order No.	NW	G	L	L ₁	ØD
Type						
BP-6	KY 8915	6	M12x1.25	92	140	1.5
BP-9	KY 8916	9	M12x1.25	92	140	1.5

Air line accessories

– Blow guns

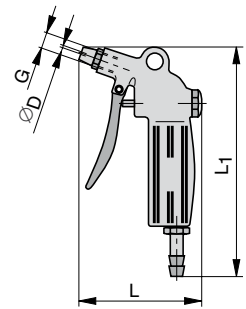

Dimensions in mm

Notice

Parker Worldwide

AE – UAE, Dubai

Tel: +971 4 8127100
parker.me@parker.com

AR – Argentina, Buenos Aires

Tel: +54 3327 44 4129

AT – Austria, Wiener Neustadt

Tel: +43 (0)2622 23501-0
parker.austria@parker.com

AT – Eastern Europe, Wiener Neustadt

Tel: +43 (0)2622 23501 900
parker.easteurope@parker.com

AU – Australia, Castle Hill

Tel: +61 (0)2-9634 7777

AZ – Azerbaijan, Baku

Tel: +994 50 2233 458
parker.azerbaijan@parker.com

BE/LU – Belgium, Nivelles

Tel: +32 (0)67 280 900
parker.belgium@parker.com

BR – Brazil, Cachoeirinha RS

Tel: +55 51 3470 9144

BY – Belarus, Minsk

Tel: +375 17 209 9399
parker.belarus@parker.com

CA – Canada, Milton, Ontario

Tel: +1 905 693 3000

CH – Switzerland, Etoy

Tel: +41 (0) 21 821 02 30
parker.switzerland@parker.com

CL – Chile, Santiago

Tel: +56 2 623 1216

CN – China, Shanghai

Tel: +86 21 5031 2525

CZ – Czech Republic, Klecany

Tel: +420 284 083 111
parker.czechrepublic@parker.com

DE – Germany, Kaarst

Tel: +49 (0)2131 4016 0
parker.germany@parker.com

DK – Denmark, Ballerup

Tel: +45 43 56 04 00
parker.denmark@parker.com

ES – Spain, Madrid

Tel: +34 902 33 00 01
parker.spain@parker.com

FI – Finland, Vantaa

Tel: +358 (0)20 753 2500
parker.finland@parker.com

FR – France, Contamine s/Arve

Tel: +33 (0)4 50 25 80 25
parker.france@parker.com

GR – Greece, Athens

Tel: +30 210 933 6450
parker.greece@parker.com

HK – Hong Kong

Tel: +852 2428 8008

HU – Hungary, Budapest

Tel: +36 1 220 4155
parker.hungary@parker.com

IE – Ireland, Dublin

Tel: +353 (0)1 466 6370
parker.ireland@parker.com

IN – India, Mumbai

Tel: +91 22 6513 7081-85

IT – Italy, Corsico (MI)

Tel: +39 02 45 19 21
parker.italy@parker.com

JP – Japan, Tokyo

Tel: +(81) 3 6408 3901

KR – South Korea, Seoul

Tel: +82 2 559 0400

KZ – Kazakhstan, Almaty

Tel: +7 7272 505 800
parker.easteurope@parker.com

LV – Latvia, Riga

Tel: +371 6 745 2601
parker.latvia@parker.com

MX – Mexico, Apodaca

Tel: +52 81 8156 6000

MY – Malaysia, Shah Alam

Tel: +60 3 7849 0800

NL – The Netherlands, Oldenzaal

Tel: +31 (0)541 585 000
parker.nl@parker.com

NO – Norway, Ski

Tel: +47 64 91 10 00
parker.norway@parker.com

NZ – New Zealand, Mt Wellington

Tel: +64 9 574 1744

PL – Poland, Warsaw

Tel: +48 (0)22 573 24 00
parker.poland@parker.com

PT – Portugal, Leca da Palmeira

Tel: +351 22 999 7360
parker.portugal@parker.com

RO – Romania, Bucharest

Tel: +40 21 252 1382
parker.romania@parker.com

RU – Russia, Moscow

Tel: +7 495 645-2156
parker.russia@parker.com

SE – Sweden, Spånga

Tel: +46 (0)8 59 79 50 00
parker.sweden@parker.com

SG – Singapore

Tel: +65 6887 6300

SK – Slovakia, Banská Bystrica

Tel: +421 484 162 252
parker.slovakia@parker.com

SL – Slovenia, Novo Mesto

Tel: +386 7 337 6650
parker.slovenia@parker.com

TH – Thailand, Bangkok

Tel: +662 717 8140

TR – Turkey, Istanbul

Tel: +90 216 4997081
parker.turkey@parker.com

TW – Taiwan, Taipei

Tel: +886 2 2298 8987

UA – Ukraine, Kiev

Tel +380 44 494 2731
parker.ukraine@parker.com

UK – United Kingdom, Warwick

Tel: +44 (0)1926 317 878
parker.uk@parker.com

US – USA, Cleveland

Tel: +1 216 896 3000

VE – Venezuela, Caracas

Tel: +58 212 238 5422

ZA – South Africa, Kempton Park

Tel: +27 (0)11 961 0700
parker.southafrica@parker.com

European Product Information Centre

Free phone: 00 800 27 27 5374

(from AT, BE, CH, CZ, DE, DK, EE, ES, FI, FR, IE, IL, IS, IT, LU, MT, NL, NO, PL, PT, RU, SE, UK, ZA)

Parker-Origa GmbH

Industriestr. 8
70794 Filderstadt, Deutschland
Tel. +49 7185 17030
Fax +49 7158 64870
www.parker-origa.com

